



# PRODUCT CATALOG





# DISCOVER

## A WORLD OF ADVANCED DENTAL SOLUTIONS



# CREATING SMILES WITH CONFIDENCE

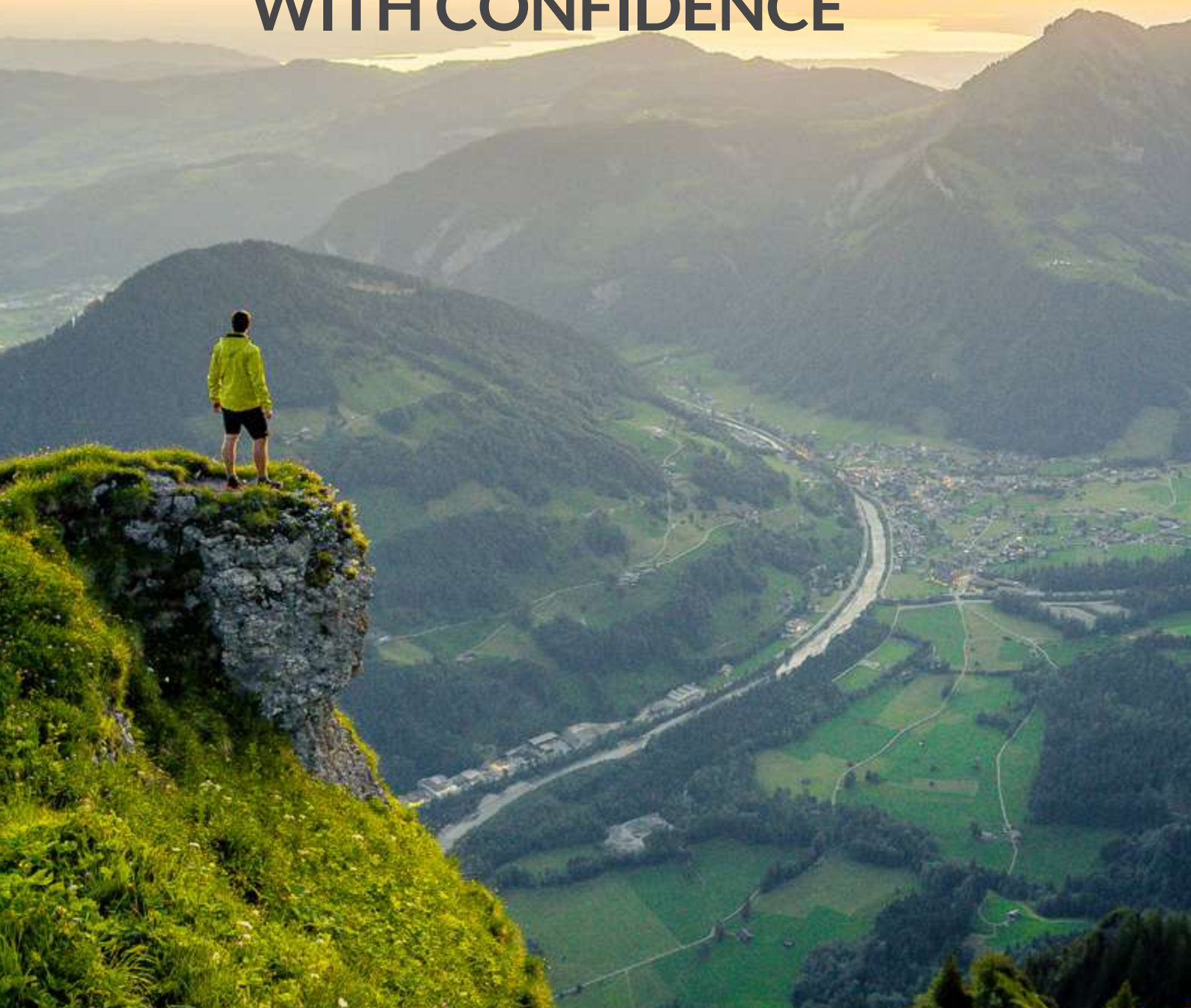

Our purpose is to provide you with simple workflows & easy to use quality implants, prosthetics & dental solutions, to enable you to perform with confidence successful dental procedures & restore your patients' smiles.



**YOUR CLINICAL SUCCESS  
& YOUR PATIENTS' HEALTH  
& ORAL FUNCTIONALITY  
ARE OUR MISSION**

Meeting your needs & exceeding your expectations are our passion!

# TABLE OF CONTENTS

## INTRODUCTION



MORE THAN 35 YEARS OF IMPROVING LIVES	9
UNCOMPROMISED QUALITY STANDARDS	10
SIMPLANTOLOGY, THE ULTIMATE SOPHISTICATION	11
BUILDING PARTNERSHIPS, DELIVERING EXCELLENCE	12
ALPHA-BIO TEC. ACADEMY, ACCELERATING YOUR PROFESSIONAL GROWTH	13

## IMPLANT SOLUTIONS



CONNECTION TYPES	17
SURFACE TECHNOLOGY	20
IMPLANT SOLUTIONS OVERVIEW	22
ADVANCED IMPLANT PACKAGE	25
MULTINEO™	26
MULTINEO POWERED BY NINA™	32
DFI™	36
SPIRAL™	40
ICE™	44
NICE™	50



## PROSTHETIC SOLUTIONS



CONICAL CONNECTION PROSTHETIC LINES	53
CONICAL STANDARD (CS) CONNECTION PROSTHETIC LINE	54
HEALING ABUTMENTS	57
IMPLANT IMPRESSION, ANALOGS & SCREWS	58
TEMPORARY ABUTMENTS	59
CEMENT-RETAINED RESTORATIONS	60
SCREW-RETAINED RESTORATIONS	61
CAD/CAM RESTORATIONS	62
OMNIBASE	64
OVERDENTURE RESTORATIONS	66
CLASSIC CS PROSTHETICS	68

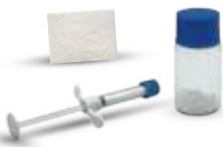

CONICAL NARROW (CHC) CONNECTION PROSTHETIC LINE	69
HEALING ABUTMENTS	71
IMPLANT IMPRESSION, ANALOGS & SCREWS	72
TEMPORARY ABUTMENTS	73
CEMENT-RETAINED RESTORATIONS	74
SCREW-RETAINED RESTORATIONS	75

	CAD/CAM RESTORATIONS	78
	OMNIBASE	80
	OVERDENTURE RESTORATIONS	82
	CLASSIC CHC PROSTHETICS	84
	<b>INTERNAL HEX (IH) PROSTHETIC LINE</b>	<b>86</b>
	HEALING ABUTMENTS	88
	TEMPORARY ABUTMENTS	89
	IMPLANT IMPRESSION	90
	IMPLANT IMPRESSION WORKFLOWS	91
	CEMENT-RETAINED RESTORATIONS	92
	CASTING ABUTMENTS, IMPLANT ANALOGS & SCREWS	95
	SCREW RETAINED RESTORATIONS	96
	CAD/CAM RESTORATIONS	98
	OVERDENTURE RESTORATIONS	102
	<hr/>	
	<b>SURGICAL INSTRUMENTS</b>	<b>104</b>
	ONE SURGICAL KIT FOR ALL IMPLANT SYSTEMS	106
	GUIDED SURGERY TOOL KIT (GSTK)	107
	DNT2 COATED DRILLS	109
	STOPPER KIT & STOPPERS	110
	SURGICAL DRILLS	111
	IMPLANT INSERTION TOOLS	112
	PROSTHETIC INSERTION TOOLS	114
	TOOLS & ACCESSORIES	115
	OMNIBASE™ TX DRIVERS	116
<hr/>		
	<b>DIGITAL SOLUTIONS</b>	<b>118</b>
	GUIDED SURGERY TOOL KIT (GSTK)	120
	CAD/CAM RESTORATIONS	125
	OMNIBASE™	128
<hr/>		
	<b>REGENERATIVE SOLUTIONS</b>	<b>130</b>
	XENOBONE™ BOVINE BONE GRAFT MATERIAL	132
	T-GEN COLLAGEN MEMBRANE	134
<hr/>		
	<b>INDEX: PRODUCT LIST</b>	<b>139</b>
	<b>LIFETIME WARRANTY</b>	<b>159</b>

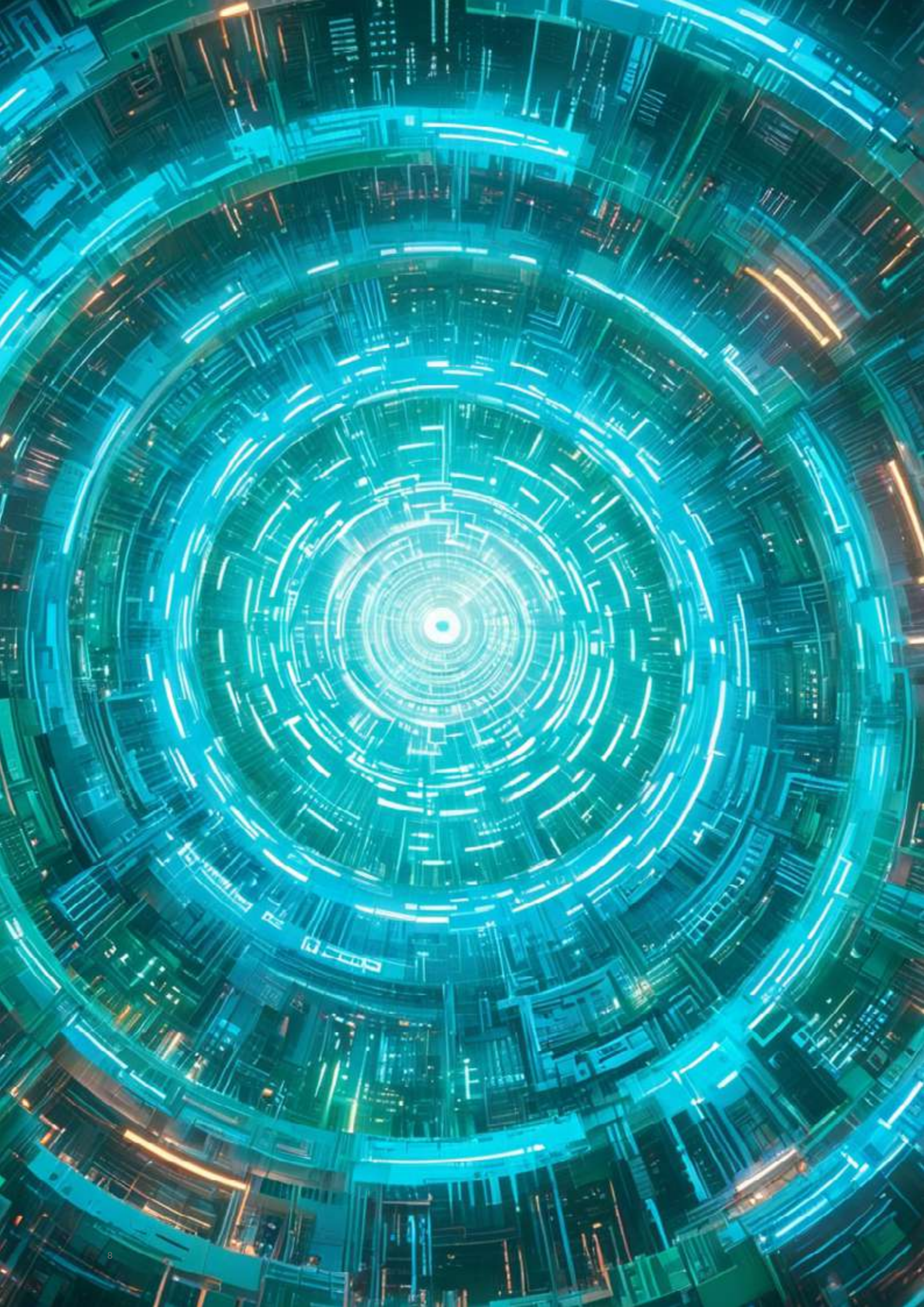





# MORE THAN 35 YEARS OF IMPROVING LIVES

For over 35 years, Alpha-Bio Tec. has become a globally recognized leader in the implantology industry, dedicated to creating simple yet sophisticated, easy to use & efficient dental solutions.

We are committed to excellence, innovation, high quality standards, reliability, and safety, by consistently providing you with trusted products, service and implantology solutions to enhance your clinical performance, confidence and predictability for optimal patient care.



# UNCOMPROMISED QUALITY STANDARDS

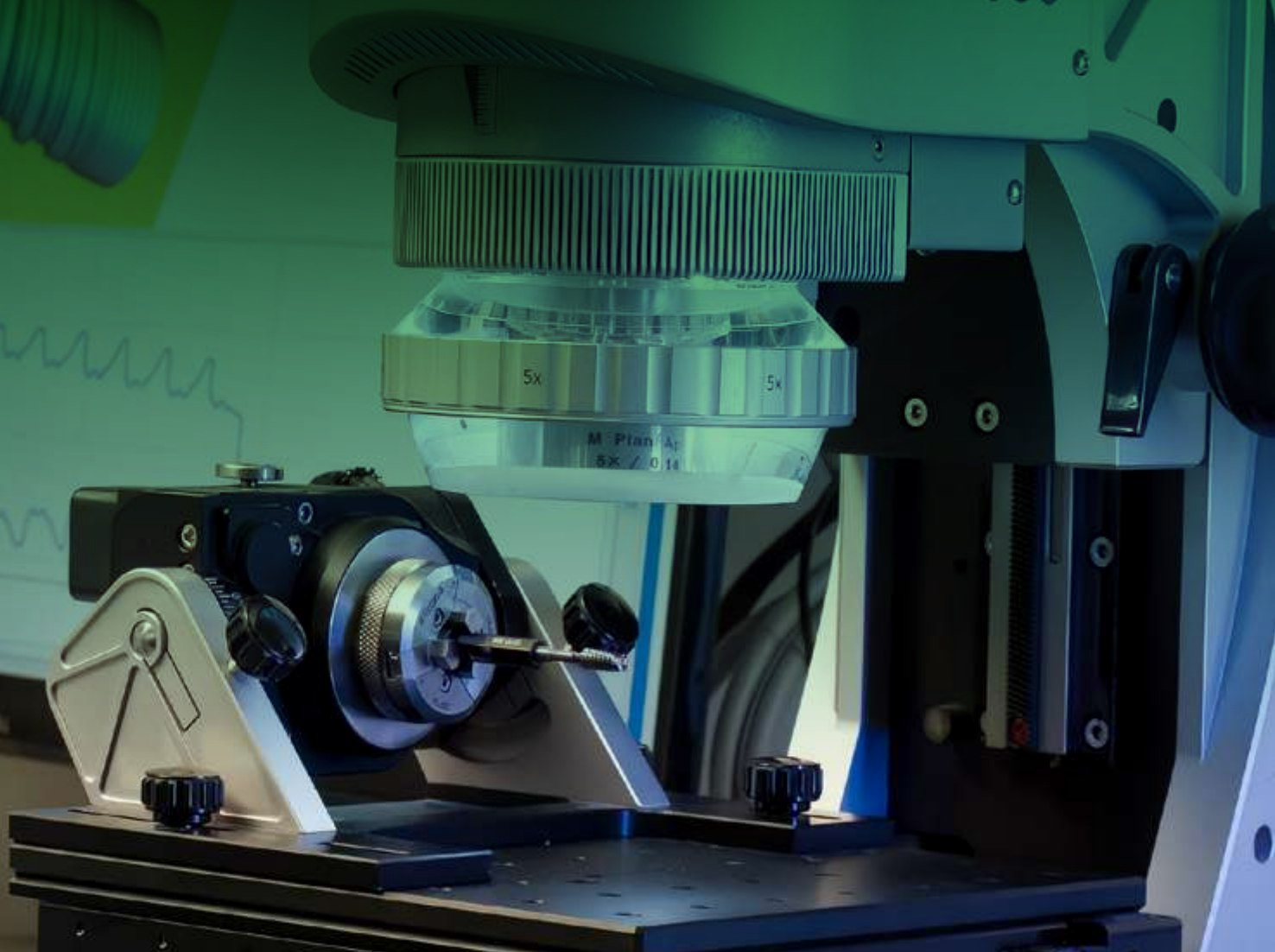

Quality is the pivotal pillar of Alpha-Bio Tec's mission & vision. We are committed to developing, manufacturing & delivering safe & effective products & dental solutions for you, our customers worldwide, & for the well-being, functionality & oral health of your patients. The implementation of our quality policy is supported by a quality management system, compliant with EN ISO 13485: Quality Management System for Medical Device Manufacturing.



# **SIMPLANTOLOGY** **THE ULTIMATE** **SOPHISTICATION**

At Alpha-Bio Tec. we are dedicated to developing dental solutions that make your daily dental workflow as easy & simple as it gets. Our implant systems, prosthetic solutions & complementary dental solutions are designed for providing you confidence, peace of mind & ease of use.

# BUILDING PARTNERSHIPS DELIVERING EXCELLENCE



Alpha-Bio Tec. partners with dozens of companies around the world, to provide you with the best customer support, service and training tools. Our global partner network is supported by skilled and experienced dental product and solution distributors. Together, we have created a dedicated community of dental industry professionals in your region – and in your language.



Visit our website to  
find a local distributor  
at your region

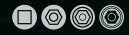

# ACCELERATING YOUR PROFESSIONAL GROWTH



At Alpha-Bio Tec. Academy we are committed to your professional growth & continuous learning, through comprehensive education programs & courses worldwide or online. Expanding your knowledge enables you to professionally perform more treatments & to improve your patients' experience & care.



Learn more about  
Alpha-Bio Tec's  
educational activities

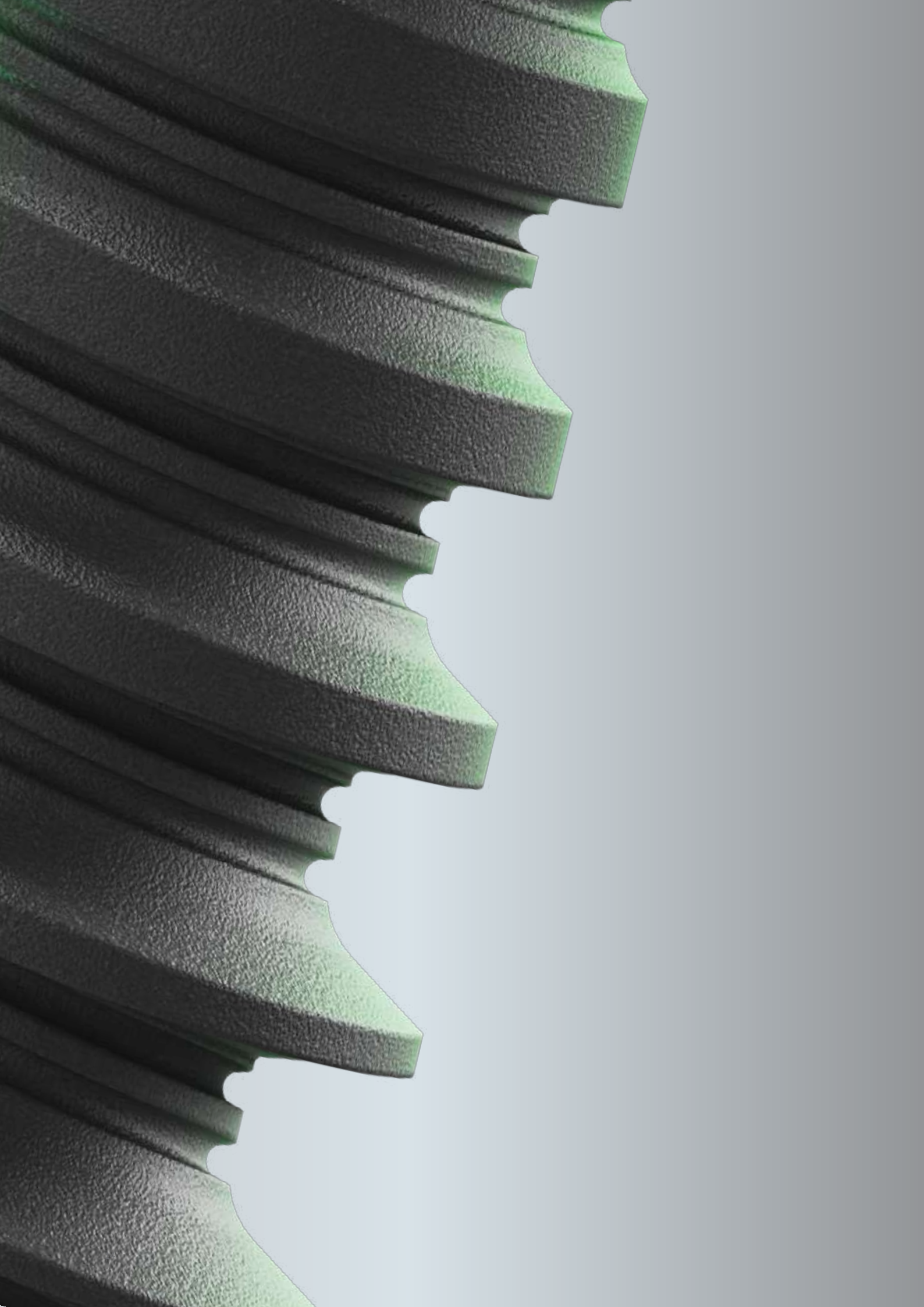



# IMPLANT SOLUTIONS

**PREDICTABILITY & CONFIDENCE  
FOR VARIOUS CLINICAL INDICATIONS**

From conical connection to internal hex connection implants, Alpha-Bio Tec. offers a range of implant solutions suitable for a variety of procedures & clinical indications, for your confidence in Every Step!





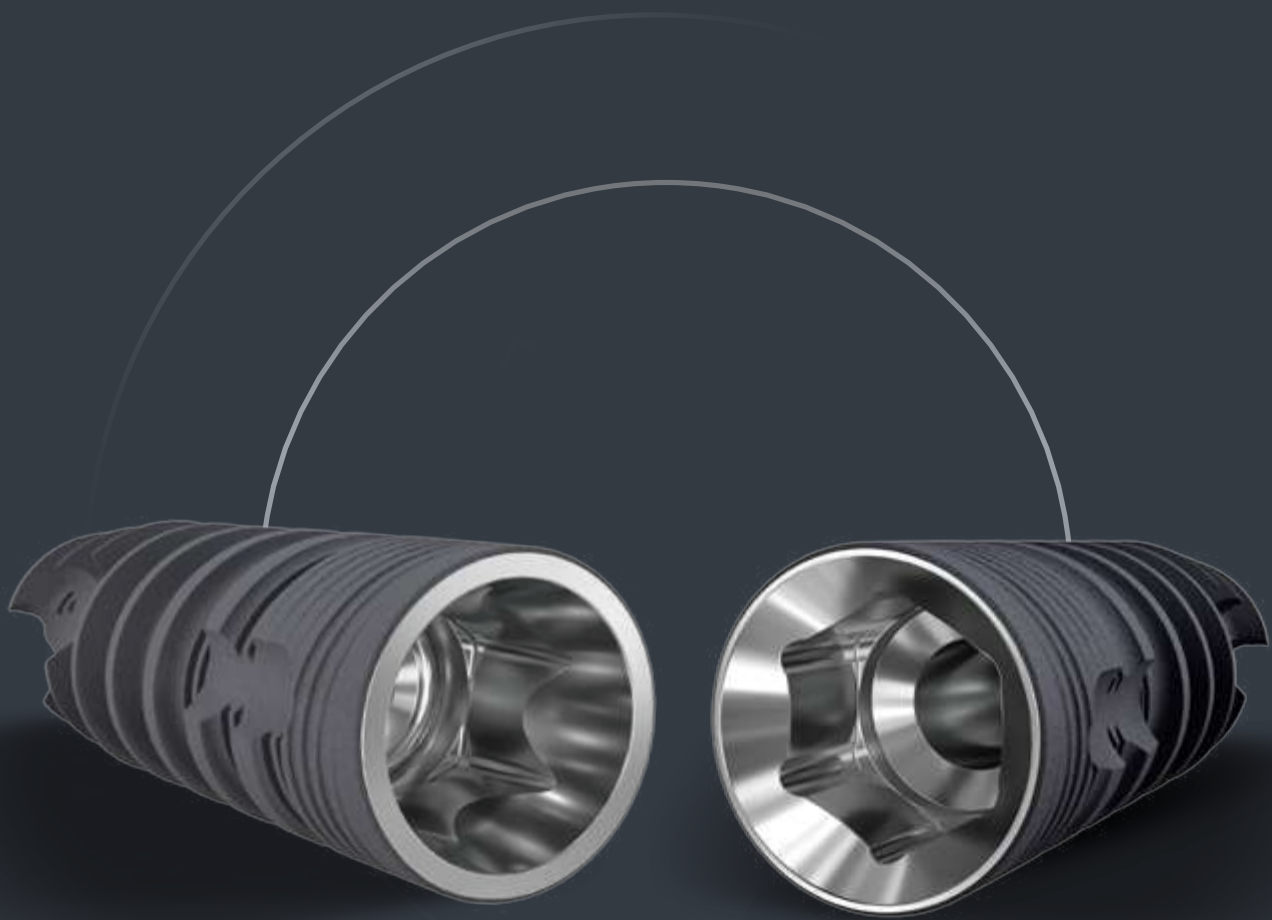

# CONNECTION TYPES

SECURE CONNECTIONS  
FOR PREDICTABILITY & ESTHETICS

Alpha-Bio Tec. offers two types of Implant-Abutment connections:



Conical Connection  
(CS & CHC)



Internal Hex Connection  
(IH)

# CONNECTION TYPES

Secure Connections for Predictability & Esthetics

## Conical Connection

Alpha-Bio Tec. Conical Connection Implants have a conical shape connection to the abutment and are available in standard diameters ( $\varnothing$  3.75 mm |  $\varnothing$  4.2 mm |  $\varnothing$  5 mm) & narrow diameters ( $\varnothing$  3.2 mm |  $\varnothing$  3.5 mm).

### CONICAL STANDARD CONNECTION

CS

$\varnothing$  3.75 mm |  $\varnothing$  4.2 mm |  $\varnothing$  5 mm

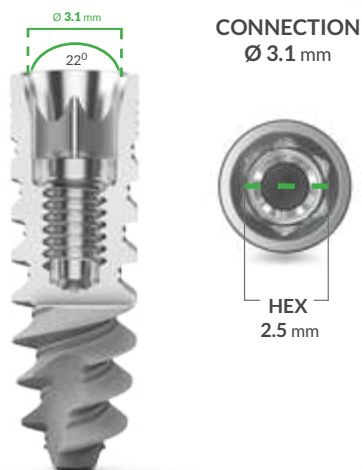

CONNECTION  
 $\varnothing$  3.1 mm

HEX  
2.5 mm

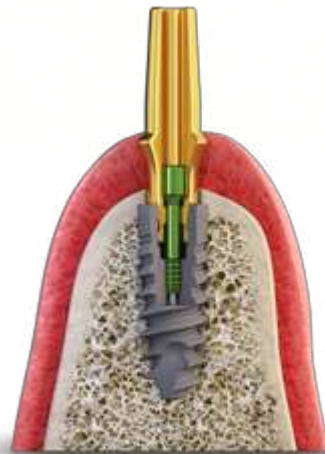

#### CS Implants:

- MultiNeO™
- MultiNeO™ powered by NiNA™
- DFI™

### CONICAL NARROW CONNECTION

CHC

$\varnothing$  3.2 mm |  $\varnothing$  3.5 mm



CONNECTION  
 $\varnothing$  2.5 mm

HEX  
2.1 mm

#### CHC Implants:

- MultiNeO™
- MultiNeO™ powered by NiNA™
- NICE™



Enhanced platform  
switching



Low bacterial  
leakage



Reduced marginal  
bone loss



Tight implant-abutment  
fit & minimal micromovements



Long term  
esthetic results

# CONNECTION TYPES

Secure Connections for Predictability & Esthetics

## Internal Hex Connection

The Internal Hex Connection is the most popular & widely used implant connection in dentistry & is considered as an industry standard. Alpha-Bio Tec. Internal Hex Connection Implants are available in various diameters, up to  $\varnothing$  6mm.

### INTERNAL HEX CONNECTION

IH

Various diameters up to  $\varnothing$  6mm

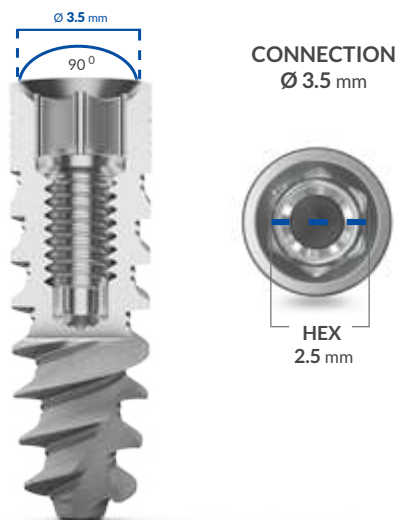

#### IH Implants:

- MultiNeO™
- DFI™
- SPIRAL™
- ICE™



High stability  
to lateral forces



High stability of the  
implant screw



Long term  
proven results



Simple restoration  
process



# SURFACE TECHNOLOGY

SURFACE TREATMENT FOR ENHANCED  
PREDICTABILITY & CLINICAL SUCCESS

All Alpha-Bio Tec. implants are made from titanium alloy Ti 6Al 4V ELI, a strong, durable, & highly bio-compatible material, and undergo mechanical & chemical surface modification processes, for increased implant surface area, enhanced bone-to-implant-contact & high survival rates.

## NANOTEC™

NanoTec micron level implant surface is achieved through a mechanical & chemical surface modification process, which involves sandblasting and double thermal acid etching, for the creation of micropores (sized 1-5 microns).

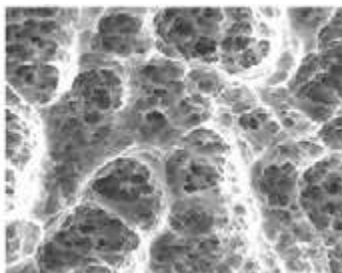

Micro level X 3k

The NanoTec process creates a high surface area, greatly influences the initial contact with the host bone and contributes to:

- Excellent osseointegration
- High long-term BIC (Bone to Implant Contact)
- Increased secondary stability

## NiNA NANO HYDROPHILIC SURFACE

The innovative super-hydrophilic nanostructure surface consists of multiple levels:

- The basic micron level (1-5 microns) produced from the known and trusted sandblasted and acid etched treatment
- New innovative TiO<sub>2</sub> (Titanium Oxide) structures on the nanometric level
- A protective layer deployed on the implant to maintain the titanium's natural hydrophilic properties

Visible nanoscale TiO<sub>2</sub> structures increase surface area and actively promote osteoblast bone formation. The active attraction of osteoblasts, combined with surface hydrophilicity, enhances a biological response accelerating wound healing processes & increased BIC for enhanced confidence & predictability.

### Micro level

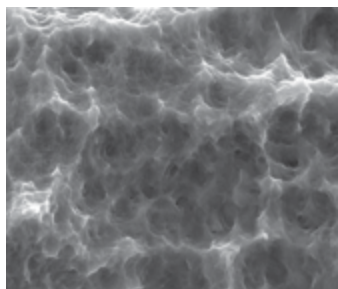

(A) Micro level X 15k

### Nano level

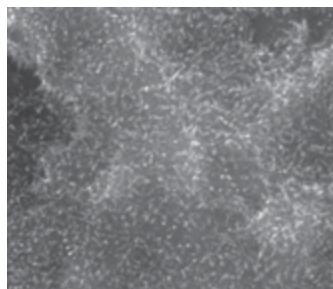

(B) Nano Level X 200k  
with nanostructures

SEM images: 15k magnification of a sandblasted and acid-etched implant (A) vs. 200k magnification of NiNA surface treatment (B), demonstrating TiO<sub>2</sub> structures growth.

# IMPLANT SOLUTIONS OVERVIEW

## MULTINEO™

### MAXIMIZE ON IMMEDIACY

The MultiNeO implant enables multiple options & multiple solutions for a variety of procedures & clinical indications, from immediate implantation & immediate loading to sinus augmentation, bone defects, narrow alveolar ridges and more.



- **Conical Standard Connection (CS)**
- **Conical Narrow Connection (CHC)**
- **Internal Hex Connection (IH)**



High primary stability



Increased surface area & BIC (Bone-Implant-Contact)



Reduced marginal bone loss



Comprehensive restoration process with high esthetic results

## MULTINEO™ | POWERED BY NiNA

### EMPOWERING PREDICTABILITY & PERFORMANCE IN IMMEDIACY

The MultiNeO powered by NiNA implant embodies the perfect synergy between an innovative implant and an advanced Nano Hydrophilic Surface enabling faster treatment and healing time and optimal patient care.



- **Conical Standard Connection (CS)**
- **Conical Narrow Connection (CHC)**



High primary stability



Enhanced osseointegration & increased BIC



High clinical predictability



Fast healing process

# IMPLANT SOLUTIONS OVERVIEW

## DFI™

A CYLINDRICAL IMPLANT YOU CAN RELY UPON WITH CONFIDENCE

The DFI implant is one of Alpha-Bio Tec.'s Legacy solutions. It is a cylindrical, slightly tapered implant, suitable for all bone types & a variety of clinical indications. From a single tooth to full arch restoration, the DFI implant is easily stabilized & controlled during placement & enables you to achieve long term stability, predictable esthetic results & high clinical success rates.



- **Conical Standard Connection (CS)**
- **Internal Hex Connection (IH)**



Good primary stability



Controlled & smooth insertion



Large surface area



Slightly tapered apex

## SPIRAL™

ALPHA-BIO TEC.'S FIRST TAPERED INTERNAL HEX IMPLANT!

The SPIRAL implant is one of the most widely used implants by Alpha-Bio Tec.'s customers around the world as it a legacy dental solution for a variety of procedures with years of proven clinical success. The Spiral implant is designed with an internal hex connection and is available in a variety of implant diameters & lengths.



- **Internal Hex Connection (IH)**



High primary stability



Increased BIC (Bone-Implant-Contact)



Supports a wide range of clinical indications



Easy & smooth insertion

# IMPLANT SOLUTIONS OVERVIEW

## ICE™

### A CLASSICAL IMPLANT FOR CONTROLLED BONE PENETRATION

The ICE implant is a moderately tapered implant, suitable for a wide range of clinical cases and enables improved bone preservation & controlled bone penetration.



- **Internal Hex Connection (IH)**

Controlled bone penetration

Good primary stability

Improved stress distribution

Supports a wide range of clinical indications

## NICE™

### AN ULTIMATE SOLUTION FOR NARROW RIDGES

The NICE Implant is a moderately tapered  $\varnothing$  3.2 implant with a conical connection, suitable for implantation in narrow ridges & limited space.



- **Conical Narrow Connection (CHC)**

Controlled bone penetration

Good primary stability

Improved stress distribution

Supports a wide range of clinical cases



# ADVANCED IMPLANT PACKAGE

Designed for Maximum Convenience and Enhanced Ergonomics



DESIGNED TO BE OPENED SINGLE HANDEDLY!

MOUNT-LESS PACKAGE WITH ADVANCED GRIP DRIVERS



COLOR-CODED HOLDER & IDENTIFICATION LABELS



SELF-STACKABLE AND INTERLOCKING FOR EASY & EFFICIENT STORAGE



1

Tear the cardboard



2

Pull the Tyvek®



3

Remove the inner holder

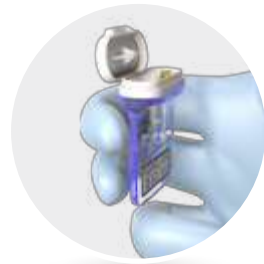

4

Open the cap - easy one-hand operation



5

Insert the dedicated driver clockwise (Ratchet wrench is for illustration purposes only)



6

Remove the connected implant from the package

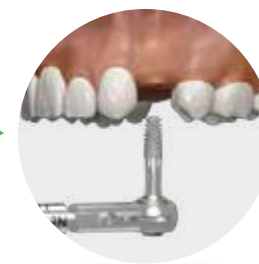

7

Implant can be inserted directly to site



8

Remove cover screw using an appropriate prosthetic driver

# MULTINEO Maximize on Immediacy



The MultiNeO implant is a tapered implant designed for immediate implant placement. It enables multiple options & multiple solutions for a variety of procedures & clinical indications, from immediate implantation & immediate loading to sinus augmentation, extreme bone defects, narrow alveolar ridges and more.

A comprehensive prosthetic line is available for all MultiNeO implant connections:



Conical Standard  
Connection (CS)



Conical Narrow  
Connection (CHC)



Internal Hex  
Connection (IH)

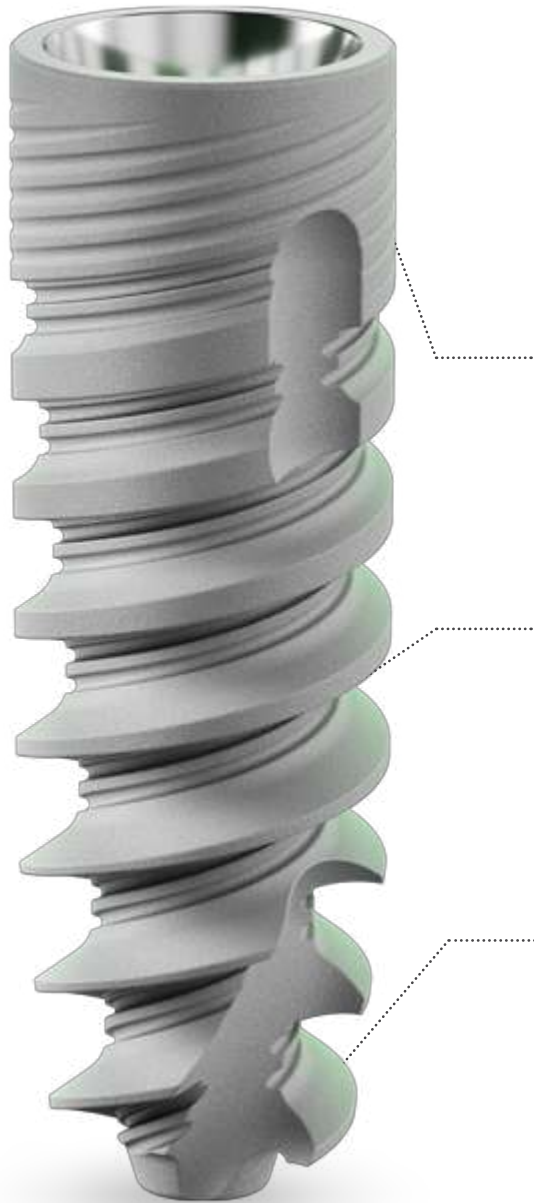

**MICRO THREADS, CUTTING FLUTES  
& PLATFORM SWITCHING**

- Reduced pressure on cortical region
- Improved bone preservation
- High initial stability

**SLIGHTLY TAPERED BODY,  
TAPERED CORE, VARIABLE THREADS  
WITH MICRO THREADS**

- High cutting efficiency
- Fast and controlled insertion
- Increased surface area
- Increased BIC

**NARROW APEX WITH PATENTED  
CENTERING FEATURE**

- Easy navigation and penetration
- Efficient cutting capability
- High primary stability



High primary  
stability



Increased BIC  
(Bone-Implant-Contact)



Reduced marginal  
bone loss



Comprehensive  
restoration process for  
high esthetic results

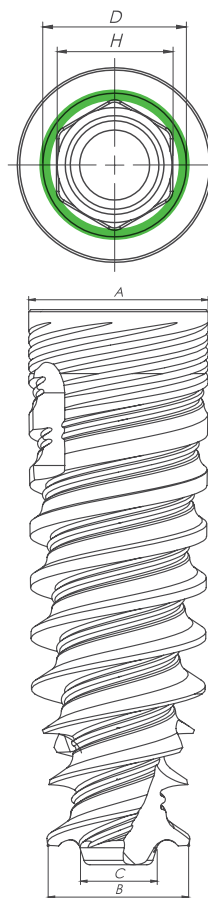

 Conical Standard Connection (CS)

Diameter	Length	Ref. No.	Dimensions				
			A	B	C	D	H
Ø 3.75 	8 mm	1938	Ø 3.75	Ø 3.1	Ø 1.8	Ø 3.1	2.5
	10 mm	1930	Ø 3.75	Ø 2.9	Ø 1.5	Ø 3.1	2.5
	11.5 mm	1931	Ø 3.75	Ø 2.9	Ø 1.5	Ø 3.1	2.5
	13 mm	1933	Ø 3.75	Ø 2.9	Ø 1.5	Ø 3.1	2.5
	16 mm	1936	Ø 3.75	Ø 2.9	Ø 1.5	Ø 3.1	2.5
Ø 4.2 	8 mm	1948	Ø 4.2	Ø 3.5	Ø 1.8	Ø 3.1	2.5
	10 mm	1940	Ø 4.2	Ø 3.3	Ø 1.8	Ø 3.1	2.5
	11.5 mm	1941	Ø 4.2	Ø 3.3	Ø 1.8	Ø 3.1	2.5
	13 mm	1943	Ø 4.2	Ø 3.3	Ø 1.8	Ø 3.1	2.5
	16 mm	1946	Ø 4.2	Ø 3.3	Ø 1.8	Ø 3.1	2.5
Ø 5.0 	8 mm	1958	Ø 5.0	Ø 4.4	Ø 2.6	Ø 3.1	2.5
	10 mm	1950	Ø 5.0	Ø 4.1	Ø 2.3	Ø 3.1	2.5
	11.5 mm	1951	Ø 5.0	Ø 4.1	Ø 2.3	Ø 3.1	2.5
	13 mm	1953	Ø 5.0	Ø 4.1	Ø 2.3	Ø 3.1	2.5



For Conical Standard Connection (CS) prosthetic solutions, see pages 57-70

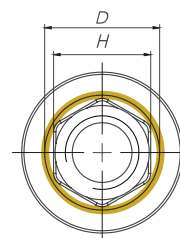

 Conical Narrow Connection (CHC)

Diameter	Length	Ref. No.	Dimensions				
			A	B	C	D	H
Ø 3.2 	8 mm	1908	Ø 3.2	Ø 2.9	Ø 1.5	Ø 2.5	2.1
	10 mm	1900	Ø 3.2	Ø 2.9	Ø 1.5	Ø 2.5	2.1
	11.5 mm	1901	Ø 3.2	Ø 2.9	Ø 1.5	Ø 2.5	2.1
	13 mm	1903	Ø 3.2	Ø 2.9	Ø 1.5	Ø 2.5	2.1
	16 mm	1906	Ø 3.2	Ø 2.9	Ø 1.5	Ø 2.5	2.1
Ø 3.5 	8 mm	1928	Ø 3.5	Ø 2.9	Ø 1.5	Ø 2.5	2.1
	10 mm	1920	Ø 3.5	Ø 2.9	Ø 1.5	Ø 2.5	2.1
	11.5 mm	1921	Ø 3.5	Ø 2.9	Ø 1.5	Ø 2.5	2.1
	13 mm	1923	Ø 3.5	Ø 2.9	Ø 1.5	Ø 2.5	2.1
	16 mm	1926	Ø 3.5	Ø 2.9	Ø 1.5	Ø 2.5	2.1

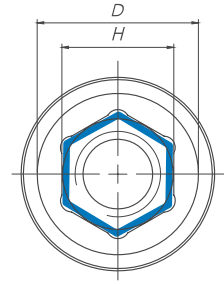

For Conical Narrow Connection (CHC) prosthetic solutions, see pages 71-85



Diameter	Length	Ref. No.	Dimensions				
			A	B	C	D	H
<b>Ø 3.75</b> 	8 mm	1968	Ø 3.75	Ø 3.1	Ø 1.8	Ø 3.5	2.5
	10 mm	1960	Ø 3.75	Ø 2.9	Ø 1.5	Ø 3.5	2.5
	11.5 mm	1961	Ø 3.75	Ø 2.9	Ø 1.5	Ø 3.5	2.5
	13 mm	1963	Ø 3.75	Ø 2.9	Ø 1.5	Ø 3.5	2.5
	16 mm	1966	Ø 3.75	Ø 2.9	Ø 1.5	Ø 3.5	2.5
<b>Ø 4.2</b> 	8 mm	1978	Ø 4.2	Ø 3.5	Ø 1.8	Ø 3.5	2.5
	10 mm	1970	Ø 4.2	Ø 3.3	Ø 1.8	Ø 3.5	2.5
	11.5 mm	1971	Ø 4.2	Ø 3.3	Ø 1.8	Ø 3.5	2.5
	13 mm	1973	Ø 4.2	Ø 3.3	Ø 1.8	Ø 3.5	2.5
	16 mm	1976	Ø 4.2	Ø 3.3	Ø 1.8	Ø 3.5	2.5
<b>Ø 5</b> 	8 mm	1988	Ø 5.0	Ø 4.4	Ø 2.6	Ø 3.5	2.5
	10 mm	1980	Ø 5.0	Ø 4.1	Ø 2.3	Ø 3.5	2.5
	11.5 mm	1981	Ø 5.0	Ø 4.1	Ø 2.3	Ø 3.5	2.5
	13 mm	1983	Ø 5.0	Ø 4.1	Ø 2.3	Ø 3.5	2.5

For **Internal Hex Connection (IH)** prosthetic solutions, see pages 86-103



STEP DRILLING SEQUENCE



Bone Type IV	Bone Type II & III		Bone Type I		
Ø2.0 	Ø2.0 	Ø2.4/Ø2.8 	Ø2.0 	Ø2.4/Ø2.8 	Ø2.8/Ø3.0 



Bone Type IV	Bone Type II & III			Bone Type I			
Ø2.0 	Ø2.0/Ø2.4 	Ø2.0 	Ø2.4/Ø2.8 	Ø2.8/Ø3.0 	Ø2.0 	Ø2.4/Ø2.8 	Ø2.8/Ø3.2 



Bone Type IV		Bone Type II & III			Bone Type I			
Ø2.0 	Ø2.4/Ø2.8 	Ø2.0 	Ø2.4/Ø2.8 	Ø2.8/Ø3.2 	Ø2.0 	Ø2.4/Ø2.8 	Ø2.8/Ø3.2 	Ø3.2/Ø3.65 Cortical* 



Bone Type IV			Bone Type II & III			Bone Type I			
Ø2.0 	Ø2.4/Ø2.8 	Ø2.8/Ø3.2 	Ø2.0 	Ø2.4/Ø2.8 	Ø3.2/Ø3.65 	Ø2.0 	Ø2.4/Ø2.8 	Ø3.2/Ø3.65 	Ø3.65/Ø4.1 Cortical* 



Bone Type IV			Bone Type II & III				Bone Type I					
Ø2.0 	Ø2.4 / Ø2.8 	Ø3.2 / Ø3.65 	Ø2.0 	Ø2.4 / Ø2.8 	Ø3.2 / Ø3.65 	Ø3.65 / Ø4.1 	Ø2.0 	Ø2.4 / Ø2.8 	Ø3.2 / Ø3.65 	Ø3.65 / Ø4.1 	Ø4.1 / Ø4.5 	Ø4.5 / Ø4.8 Cortical* 



\*Cortical - Drill through cortical plate.



STRAIGHT DRILLING SEQUENCE



Bone Type IV				Bone Type II & III			Bone Type I		
Ø 2.0	Ø 2.0	Ø 2.4	Ø 2.8*	Ø 2.0	Ø 2.8	Ø 3.0*	Ø 2.0	Ø 2.8	Ø 3.0*



Bone Type IV		Bone Type II & III			Bone Type I		
Ø 2.0	Ø 2.4*	Ø 2.0	Ø 2.8	Ø 3.0*	Ø 2.0	Ø 2.8	Ø 3.2*



\* 3mm shorter than implant's length.



Bone Type IV			Bone Type II & III			Bone Type I			
Ø 2.0	Ø 2.4	Ø 2.8**	Ø 2.0	Ø 2.8	Ø 3.2**	Ø 2.0	Ø 2.8	Ø 3.2**	Ø 3.65 Cortical*



Bone Type IV			Bone Type II & III				Bone Type I				
Ø 2.0	Ø 2.8	Ø 3.2**	Ø 2.0	Ø 2.8	Ø 3.2	Ø 3.65**	Ø 2.0	Ø 2.8	Ø 3.2	Ø 3.65**	Ø 4.1 Cortical*



Bone Type IV				Bone Type II & III					Bone Type I						
Ø 2.0	Ø 2.8	Ø 3.2	Ø 3.65**	Ø 2.0	Ø 2.8	Ø 3.2	Ø 3.65	Ø 4.1**	Ø 2.0	Ø 2.8	Ø 3.2	Ø 3.65	Ø 4.1	Ø 4.5**	Ø 4.8 Cortical*



\* **Cortical** - Drill through cortical plate.

\*\* 3mm shorter than implant's length. Note that drill can be replaced by a corresponding step drill throughout entire implant's length. For more information, see step protocol.

**Important:** Professional discretion is advised for adaptations of the drilling sequence in different clinical cases.

# MULTINEO™



## Empowering Predictability & Performance in Immediacy

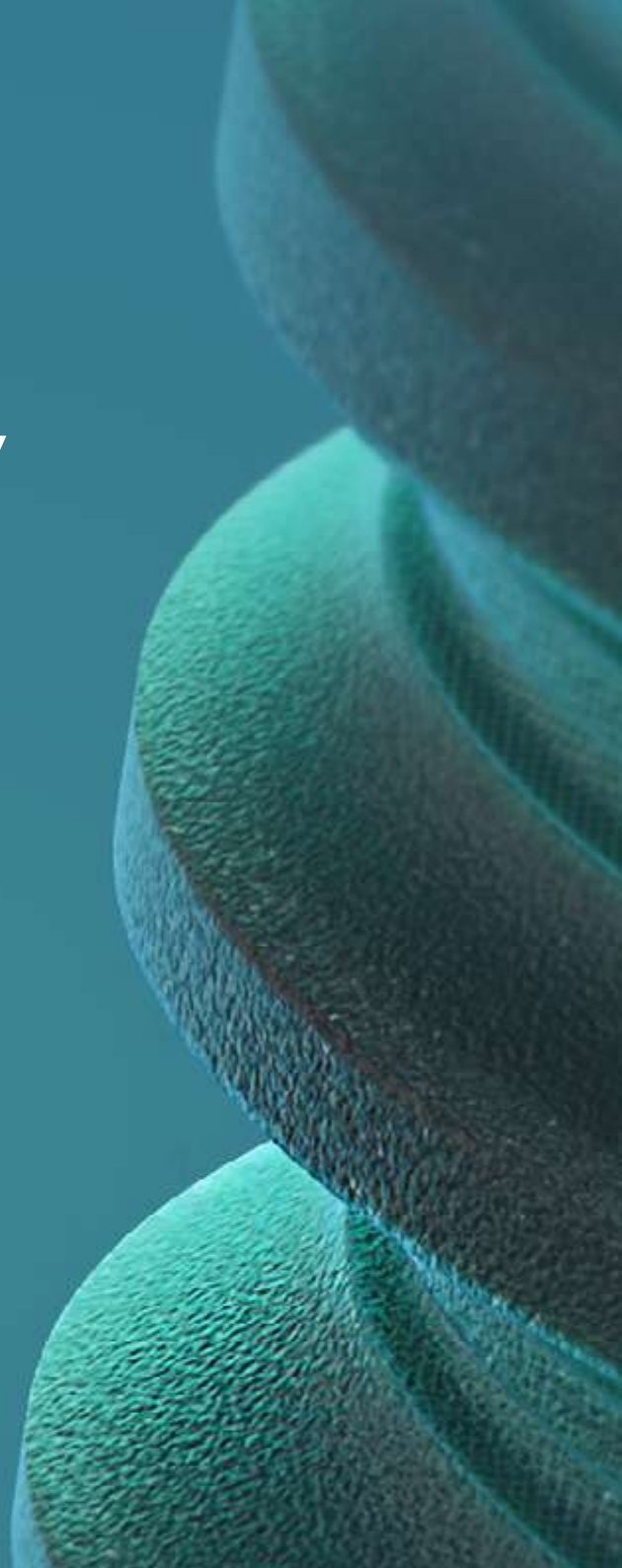

MultiNeO™ powered by NiNA™ embodies the synergy between an innovative implant and an advanced nano hydrophilic surface, enabling you to enhance your clinical performance and confidence in immediate implant and loading procedures, due to enhanced bone formation and faster healing time for optimal patient care.

A comprehensive conical connection prosthetic line is available for all MultiNeO powered by NiNA implants:



Conical Standard Connection (CS)



Conical Narrow Connection (CHC)



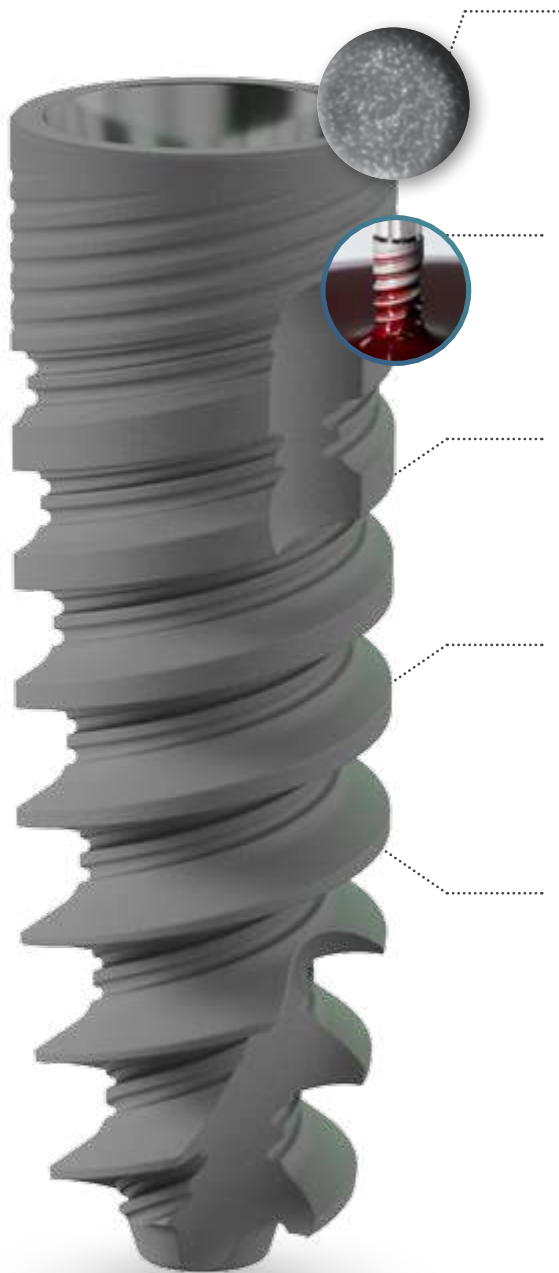

**NANO STRUCTURES**

Visible nanoscale TiO<sub>2</sub> structures increase surface area and actively promote osteoblast bone formation

**IMPLANT HYDROPHILICITY**

NiNA hydrophilic surface contributes to accelerated blood and bone attraction, and increased BIC

**SPECIAL CUTTING FLUTES & MICRO THREADS**

- Reduced pressure on cortical bone
- Improved bone preservation
- High primary stability

**INNOVATIVE THREAD DESIGN WITH TWO MICRO THREADS AND SHARP ATTACK ANGLE**

- High cutting efficiency
- High primary stability in all bone types
- Greater surface area (BIC)

**UNIQUE PATENTED CENTERING FEATURE & SHARP AND DEEP THREADS**

- High primary engagement
- Easy navigation and penetration
- High cutting efficiency

**DRY IMPLANT PACKAGE**

Patented technology allows for a dry implant package with ultra-hydrophilicity maintained



High primary stability



Enhanced osseointegration & increased BIC





High clinical predictability



Fast healing process

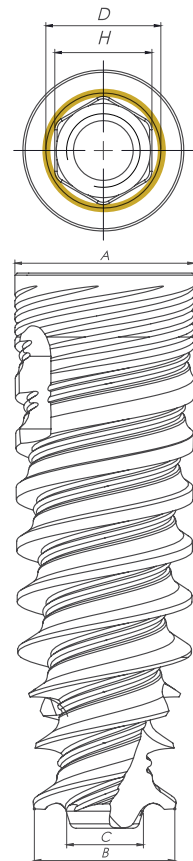

 Conical Narrow Connection (CHC)

Diameter	Length	Ref. No.	Dimensions				
			A	B	C	D	H
<b>Ø 3.2</b> 	8 mm	9308	Ø 3.2	Ø 2.9	Ø 1.5	Ø 2.5	2.1
	10 mm	9300	Ø 3.2	Ø 2.9	Ø 1.5	Ø 2.5	2.1
	11.5 mm	9301	Ø 3.2	Ø 2.9	Ø 1.5	Ø 2.5	2.1
	13 mm	9303	Ø 3.2	Ø 2.9	Ø 1.5	Ø 2.5	2.1
	16 mm	9306	Ø 3.2	Ø 2.9	Ø 1.5	Ø 2.5	2.1
<b>Ø 3.5</b> 	8 mm	9328	Ø 3.5	Ø 2.9	Ø 1.5	Ø 2.5	2.1
	10 mm	9320	Ø 3.5	Ø 2.9	Ø 1.5	Ø 2.5	2.1
	11.5 mm	9321	Ø 3.5	Ø 2.9	Ø 1.5	Ø 2.5	2.1
	13 mm	9323	Ø 3.5	Ø 2.9	Ø 1.5	Ø 2.5	2.1
	16 mm	9326	Ø 3.5	Ø 2.9	Ø 1.5	Ø 2.5	2.1



For **Conical Narrow Connection (CHC)** prosthetic solutions, see pages 71-85



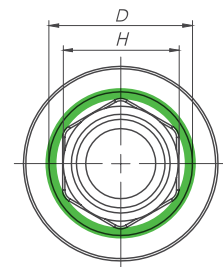

 Conical Standard Connection (CS)

Diameter	Length	Ref. No.	Dimensions				
			A	B	C	D	H
<b>Ø 3.75</b> 	8 mm	9338	Ø 3.75	Ø 3.1	Ø 1.8	Ø 3.1	2.5
	10 mm	9330	Ø 3.75	Ø 2.9	Ø 1.5	Ø 3.1	2.5
	11.5 mm	9331	Ø 3.75	Ø 2.9	Ø 1.5	Ø 3.1	2.5
	13 mm	9333	Ø 3.75	Ø 2.9	Ø 1.5	Ø 3.1	2.5
	16 mm	9336	Ø 3.75	Ø 2.9	Ø 1.5	Ø 3.1	2.5
<b>Ø 4.2</b> 	8 mm	9348	Ø 4.2	Ø 3.5	Ø 1.8	Ø 3.1	2.5
	10 mm	9340	Ø 4.2	Ø 3.3	Ø 1.8	Ø 3.1	2.5
	11.5 mm	9341	Ø 4.2	Ø 3.3	Ø 1.8	Ø 3.1	2.5
	13 mm	9343	Ø 4.2	Ø 3.3	Ø 1.8	Ø 3.1	2.5
	16 mm	9346	Ø 4.2	Ø 3.3	Ø 1.8	Ø 3.1	2.5
<b>Ø 5.0</b> 	8 mm	9358	Ø 5.0	Ø 4.4	Ø 2.6	Ø 3.1	2.5
	10 mm	9350	Ø 5.0	Ø 4.1	Ø 2.3	Ø 3.1	2.5
	11.5 mm	9351	Ø 5.0	Ø 4.1	Ø 2.3	Ø 3.1	2.5
	13 mm	9353	Ø 5.0	Ø 4.1	Ø 2.3	Ø 3.1	2.5







For **Conical Standard Connection (CS)** prosthetic solutions, see pages 57-70

### STEP DRILLING SEQUENCE

	Bone Type IV			Bone Type II & III			Bone Type I							
Ø 3.2	Ø2.0			Ø2.0	Ø2.4/Ø2.8		Ø2.0	Ø2.4/Ø2.8	Ø2.8/Ø3.0					
Ø 3.5	Ø2.0	Ø2.0/Ø2.4		Ø2.0	Ø2.4/Ø2.8	Ø2.8/Ø3.0	Ø2.0	Ø2.4/Ø2.8	Ø2.8/Ø3.2					
Ø 3.75	Ø2.0	Ø2.4/Ø2.8		Ø2.0	Ø2.4/Ø2.8	Ø2.8/Ø3.2	Ø2.0	Ø2.4/Ø2.8	Ø2.8/Ø3.2	Ø3.2/Ø3.65 Cortical*				
Ø 4.2	Ø2.0	Ø2.4/Ø2.8	Ø2.8/Ø3.2	Ø2.0	Ø2.4/Ø2.8	Ø3.2/Ø3.65	Ø2.0	Ø2.4/Ø2.8	Ø3.2/Ø3.65	Ø3.65/Ø4.1 Cortical*				
Ø 5.0	Ø2.0	Ø2.4 / Ø2.8	Ø3.2 / Ø3.65	Ø2.0	Ø2.4 / Ø2.8	Ø3.2 / Ø3.65	Ø3.65 / Ø4.1	Ø2.0	Ø2.4 / Ø2.8	Ø3.2 / Ø3.65	Ø3.65 / Ø4.1	Ø4.1 / Ø4.5	Ø4.5 / Ø4.8 Cortical*	

### STRAIGHT DRILLING SEQUENCE

	Bone Type IV			Bone Type II & III			Bone Type I										
Ø 3.2	Ø2.0			Ø2.0	Ø2.4	Ø2.8*	Ø2.0	Ø2.8	Ø3.0*								
Ø 3.5	Ø2.0	Ø2.4*		Ø2.0	Ø2.8	Ø3.0*	Ø2.0	Ø2.8	Ø3.2*								
Ø 3.75	Ø2.0	Ø2.4	Ø2.8**	Ø2.0	Ø2.8	Ø3.2**	Ø2.0	Ø2.8	Ø3.2**	Ø3.65 Cortical*							
Ø 4.2	Ø2.0	Ø2.8	Ø3.2**	Ø2.0	Ø2.8	Ø3.2	Ø3.65**	Ø2.0	Ø2.8	Ø3.2	Ø3.65**	Ø4.1 Cortical*					
Ø 5.0	Ø2.0	Ø2.8	Ø3.2	Ø3.65**	Ø2.0	Ø2.8	Ø3.2	Ø3.65	Ø4.1**	Ø2.0	Ø2.8	Ø3.2	Ø3.65	Ø4.1	Ø4.5**	Ø4.8 Cortical*	

\* 3mm shorter than implant's length.

\* **Cortical** - Drill through cortical plate. \*\* 3mm shorter than implant's length. Note that drill can be replaced by a corresponding step drill throughout entire implant's length. For more information, see step protocol. **Important:** Professional discretion is advised for adaptations of the drilling sequence in different clinical cases.

# DFI™

## A Cylindrical Implant You Can Rely Upon with Confidence



The DFI™ implant is one of Alpha-Bio Tec's Legacy solutions. It is a cylindrical implant with a slightly tapered apex, suitable for all bone types & a variety of clinical indications. The DFI implant is easily stabilized & controlled during placement & enables you to achieve long term stability, predictable esthetic results & high clinical success rates.

A comprehensive prosthetic line is available for all DFI implant connections:



 Conical Standard Connection (CS)



 Internal Hex Connection (IH)

# DFI A Cylindrical Implant You Can Rely Upon with Confidence

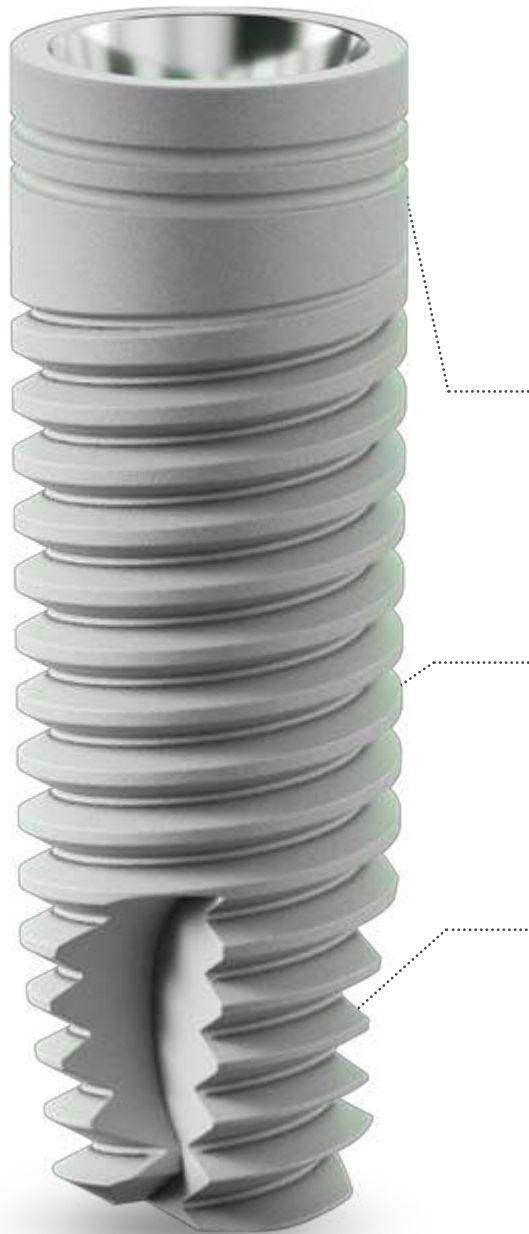

## MICRO RINGS

- Reduced marginal bone loss
- Decreased crestal compression
- Increased Bone to Implant Contact (BIC)

## CYLINDRICAL BODY WITH VARIABLE THREADS

- Increased BIC
- Efficient load distribution
- Reduced marginal bone loss

## SLIGHTLY TAPERED FLAT APEX WITH SHARP THREADS & A CUTTING FLUTE

- Good primary stability
- Increased surface area
- Smooth & controlled insertion



Good primary stability



Controlled & smooth insertion





Large surface area



Slightly tapered apex

# DFI A Cylindrical Implant You Can Rely Upon with Confidence





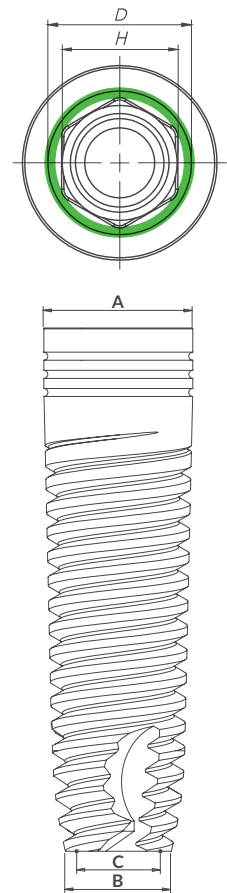

Diameter	Length	Ref. No.	Dimensions				
			A	B	C	D	H
<b>Ø 3.75</b> 	8 mm	1828	Ø 3.85	Ø 3	Ø 2.1	Ø 3.1	2.5
	10 mm	1820	Ø 3.85	Ø 3	Ø 2.1	Ø 3.1	2.5
	11.5 mm	1821	Ø 3.85	Ø 3	Ø 2.1	Ø 3.1	2.5
	13 mm	1823	Ø 3.85	Ø 3	Ø 2.1	Ø 3.1	2.5
<b>Ø 4.2</b> 	8 mm	1838	Ø 4.2	Ø 3.55	Ø 1.8	Ø 3.1	2.5
	10 mm	1830	Ø 4.2	Ø 3.3	Ø 1.8	Ø 3.1	2.5
	11.5 mm	1831	Ø 4.2	Ø 3.3	Ø 1.8	Ø 3.1	2.5
	13 mm	1833	Ø 4.2	Ø 3.3	Ø 1.8	Ø 3.1	2.5
<b>Ø 5.0</b> 	8 mm	1848	Ø 4.95	Ø 4.05	Ø 3.1	Ø 3.1	2.5
	10 mm	1840	Ø 4.95	Ø 4.05	Ø 3.1	Ø 3.1	2.5
	11.5 mm	1841	Ø 4.95	Ø 4.05	Ø 3.1	Ø 3.1	2.5
	13 mm	1843	Ø 4.95	Ø 4.05	Ø 3.1	Ø 3.1	2.5



For **Conical Standard Connection (CS)** prosthetic solutions, see pages 57-70





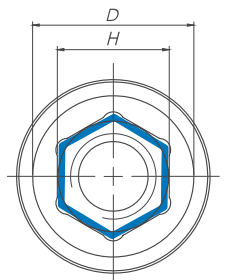



































Diameter	Length	Ref. No.	Dimensions				
			A	B	C	D	H
<b>Ø 3.3</b> 	8 mm	1288	Ø 3.7	Ø 2.6	Ø 2.1	Ø 3.5	2.5
	10 mm	1280	Ø 3.7	Ø 2.6	Ø 2.1	Ø 3.5	2.5
	11.5 mm	1281	Ø 3.7	Ø 2.6	Ø 2.1	Ø 3.5	2.5
	13 mm	1283	Ø 3.7	Ø 2.6	Ø 2.1	Ø 3.5	2.5
<b>Ø 3.75</b> 	8 mm	1268	Ø 3.85	Ø 3	Ø 2.1	Ø 3.5	2.5
	10 mm	1260	Ø 3.85	Ø 3	Ø 2.1	Ø 3.5	2.5
	11.5 mm	1261	Ø 3.85	Ø 3	Ø 2.1	Ø 3.5	2.5
	13 mm	1263	Ø 3.85	Ø 3	Ø 2.1	Ø 3.5	2.5
<b>Ø 4.2</b> 	8 mm	1278	Ø 4.2	Ø 3	Ø 2.2	Ø 3.5	2.5
	10 mm	1270	Ø 4.2	Ø 3	Ø 2.2	Ø 3.5	2.5
	11.5 mm	1271	Ø 4.2	Ø 3	Ø 2.2	Ø 3.5	2.5
	13 mm	1273	Ø 4.2	Ø 3	Ø 2.2	Ø 3.5	2.5
<b>Ø 5</b> 	8 mm	1298	Ø 4.95	Ø 4.05	Ø 3.1	Ø 3.5	2.5
	10 mm	1290	Ø 4.95	Ø 4.05	Ø 3.1	Ø 3.5	2.5
	11.5 mm	1291	Ø 4.95	Ø 4.05	Ø 3.1	Ø 3.5	2.5
	13 mm	1293	Ø 4.95	Ø 4.05	Ø 3.1	Ø 3.5	2.5



For **Internal Hex Connection (IH)** prosthetic solutions, see pages 86-103

## STRAIGHT DRILLING SEQUENCE

Ø 3.3	Bone Type IV		Bone Type II & III		Bone Type I									
	Ø2.0 	Ø2.8 Cortical* 	Ø2.0 	Ø2.8 	Ø2.0 	Ø2.8 	Ø3.2 Cortical* 							
Ø 3.75	Bone Type IV			Bone Type II & III			Bone Type I							
	Ø2.0 	Ø2.8 	Ø3.2 Cortical* 	Ø2.0 	Ø2.8 	Ø3.2 	Ø2.0 	Ø2.8 	Ø3.2 	Ø3.65 Cortical* 				
Ø 4.2	Bone Type IV				Bone Type II & III				Bone Type I					
	Ø2.0 	Ø2.8 	Ø3.2 	Ø3.65 Cortical* 	Ø2.0 	Ø2.8 	Ø3.2 	Ø3.65 	Ø2.0 	Ø2.8 	Ø3.2 	Ø3.65 	Ø4.1 Cortical* 	
Ø 5.0	Bone Type IV						Bone Type II & III							
	Ø2.0 	Ø2.8 	Ø3.2 	Ø3.65 	Ø4.1 	Ø4.5 Cortical* 	Ø2.0 	Ø2.8 	Ø3.2 	Ø3.65 	Ø4.1 	Ø4.5 		
	Bone Type I													
	Ø2.0 	Ø2.8 	Ø3.2 	Ø3.65 	Ø4.1 	Ø4.5 	Ø4.8 Cortical* 							

\* **Cortical** - Drill through cortical plate.

**Important:** Professional discretion is advised for adaptations of the drilling sequence in different clinical cases.



# SPIRAL™

## Alpha-Bio Tec.'s First Tapered Internal Hex Implant!



The SPIRAL implant is one of the most widely used implants by Alpha-Bio Tec. customers around the world as it a legacy dental solution for a variety of procedures with years of proven clinical success. The SPIRAL implant is designed with an internal hex connection and is available in a variety of implant diameters & lengths.

A comprehensive internal hex prosthetic line is available for SPIRAL implants:



Internal Hex  
Connection (IH)



# SPIRAL Alpha-Bio Tec.'s First Tapered Internal Hex Implant

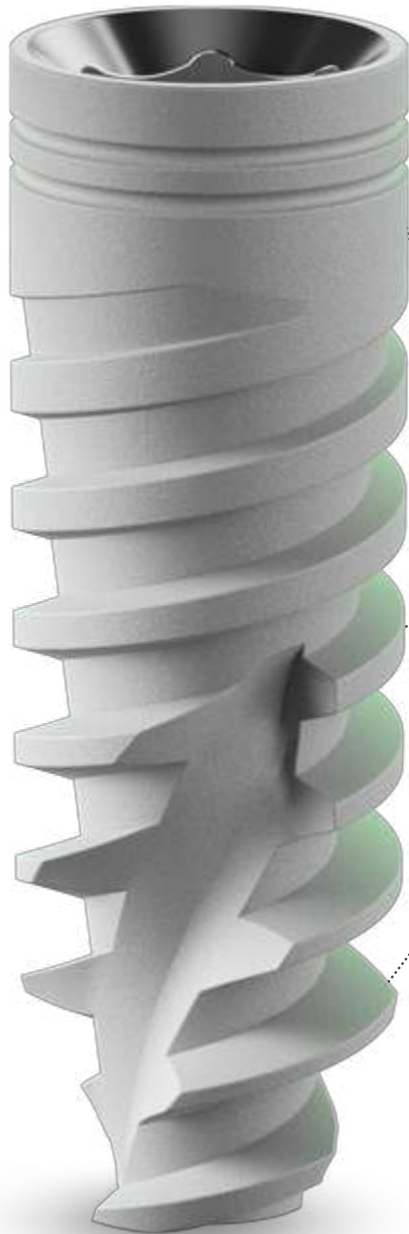

## MICRO RINGS

- Reduced marginal bone loss
- Decreased crestal stress

## SLIGHTLY TAPERED BODY, TAPERED CORE, WITH DOUBLE & VARIABLE THREADS

- Redirecting capability
- Easy insertion
- Increased BIC

## NARROW CORE & SHARP & DEEP APICAL THREADS

- Easy and smooth insertion
- High primary stability



High primary stability



Increased BIC (Bone-Implant-Contact)

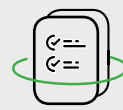





Supports a wide range of clinical indications



Easy & smooth insertion

# SPIRAL Alpha-Bio Tec's First Tapered Internal Hex Implant



Diameter	Length	Ref. No.	Dimensions				
			A	B	C	D	H
<b>Ø 3.3</b> 	8 mm	1308	Ø 3.7	Ø 2.55	Ø 1.55	Ø 3.5	2.5
	10 mm	1300	Ø 3.7	Ø 2.55	Ø 1.55	Ø 3.5	2.5
	11.5 mm	1301	Ø 3.7	Ø 2.55	Ø 1.55	Ø 3.5	2.5
	13 mm	1303	Ø 3.7	Ø 2.55	Ø 1.55	Ø 3.5	2.5
	16 mm	1306	Ø 3.7	Ø 2.55	Ø 1.55	Ø 3.5	2.5
<b>Ø 3.75</b> 	8 mm	1358	Ø 3.85	Ø 2.9	Ø 2	Ø 3.5	2.5
	10 mm	1350	Ø 3.85	Ø 2.9	Ø 2	Ø 3.5	2.5
	11.5 mm	1351	Ø 3.85	Ø 2.9	Ø 2	Ø 3.5	2.5
	13 mm	1353	Ø 3.85	Ø 2.9	Ø 2	Ø 3.5	2.5
	16 mm	1356	Ø 3.85	Ø 2.9	Ø 2	Ø 3.5	2.5
<b>Ø 4.2</b> 	8 mm	1338	Ø 4.2	Ø 3	Ø 2.1	Ø 3.5	2.5
	10 mm	1330	Ø 4.2	Ø 3	Ø 2.1	Ø 3.5	2.5
	11.5 mm	1331	Ø 4.2	Ø 3	Ø 2.1	Ø 3.5	2.5
	13 mm	1333	Ø 4.2	Ø 3	Ø 2.1	Ø 3.5	2.5
	16 mm	1336	Ø 4.2	Ø 3	Ø 2.1	Ø 3.5	2.5
<b>Ø 5</b> 	8 mm	1348	Ø 4.95	Ø 3.3	Ø 2.6	Ø 3.5	2.5
	10 mm	1340	Ø 4.95	Ø 3.3	Ø 2.6	Ø 3.5	2.5
	11.5 mm	1341	Ø 4.95	Ø 3.3	Ø 2.6	Ø 3.5	2.5
	13 mm	1343	Ø 4.95	Ø 3.3	Ø 2.6	Ø 3.5	2.5
	16 mm	1346	Ø 4.95	Ø 3.3	Ø 2.6	Ø 3.5	2.5
<b>Ø 6</b> 	8 mm	1368	Ø 5.95	Ø 4.6	Ø 3.35	Ø 3.5	2.5
	10 mm	1360	Ø 5.95	Ø 4.6	Ø 3.45	Ø 3.5	2.5
	11.5 mm	1361	Ø 5.95	Ø 4.6	Ø 3.45	Ø 3.5	2.5
	13 mm	1363	Ø 5.95	Ø 4.6	Ø 3.45	Ø 3.5	2.5

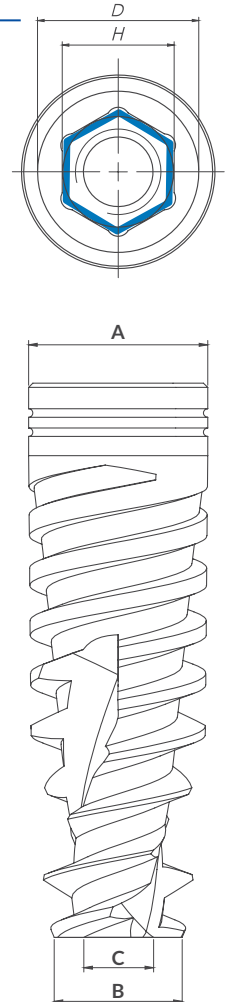

For **Internal Hex Connection (IH)** prosthetic solutions, see pages 86-103

# SPIRAL Alpha-Bio Tec's First Tapered Internal Hex Implant

## STRAIGHT DRILLING SEQUENCE

Ø 3.3

Bone Type IV	Bone Type II & III		Bone Type I		
Ø2.0	Ø2.0	Ø2.8	Ø2.0	Ø2.8	Ø3.2 Cortical*



Ø 3.75

Bone Type IV		Bone Type II & III			Bone Type I			
Ø2.0	Ø2.8	Ø2.0	Ø2.8	Ø3.2	Ø2.0	Ø2.8	Ø3.2	Ø3.65 Cortical*



Ø 4.2

Bone Type IV			Bone Type II & III				Bone Type I				
Ø2.0	Ø2.8	Ø3.2	Ø2.0	Ø2.8	Ø3.2	Ø3.65	Ø2.0	Ø2.8	Ø3.2	Ø3.65	Ø4.1 Cortical*



Ø 5.0

Bone Type IV				Bone Type II & III					
Ø2.0	Ø2.8	Ø3.2	Ø3.65	Ø2.0	Ø2.8	Ø3.2	Ø3.65	Ø4.1	Ø4.5

Bone Type I							
Ø2.0	Ø2.8	Ø3.2	Ø3.65	Ø4.1	Ø4.5	Ø4.8 Cortical*	



Ø 6.0

Bone Type IV						Bone Type II & III						
Ø2.0	Ø2.8	Ø3.2	Ø3.65	Ø4.1	Ø4.8	Ø2.0	Ø2.8	Ø3.2	Ø3.65	Ø4.1	Ø4.8	Ø5.2

Bone Type I							
Ø2.0	Ø2.8	Ø3.2	Ø3.65	Ø4.1	Ø4.8	Ø5.2	Ø5.8 Cortical*



\* **Cortical** – Drill through cortical plate.

**Important:** Professional discretion is advised for adaptations of the drilling sequence in different clinical cases.

# ICE™

## A Classical Implant for Controlled Bone Penetration!



The ICE™ implant is a moderately tapered implant, suitable for a wide range of clinical cases and enables improved bone preservation & controlled bone penetration.

A comprehensive internal hex prosthetic line is available for ICE implants:



Internal Hex  
Connection (IH)

# ICE A Classical Implant for Controlled Bone Penetration

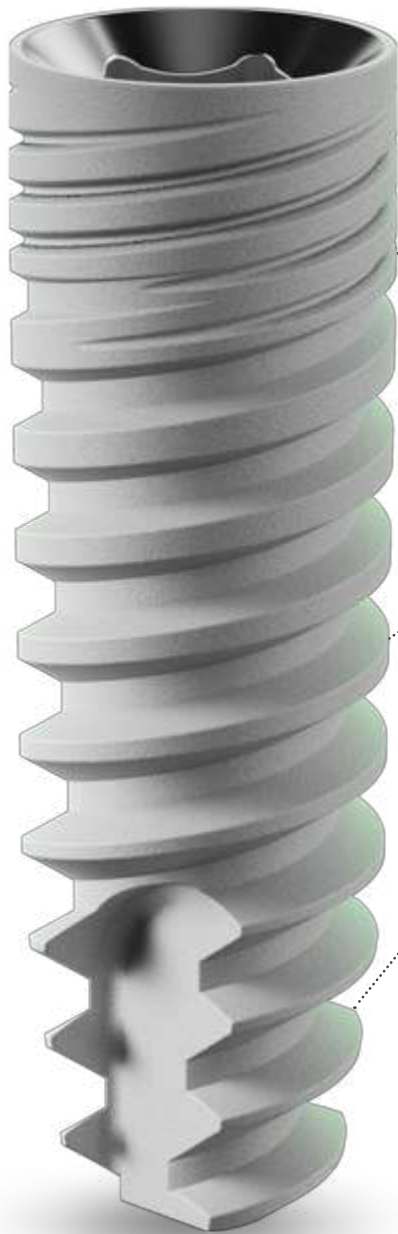

## MICRO THREADS

- Reduced marginal bone loss
- Decreased crestal stress
- Increased Bone Implant Contact (BIC)

## MODERATELY TAPERED BODY AND CORE

- Smooth & controlled insertion
- Good primary stability

## TAPERED APEX WITH SHARP & DEEP THREADS

- Smooth and controlled insertion
- Good primary stability



Controlled bone penetration

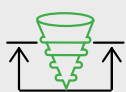

Good primary stability



Improved stress distribution

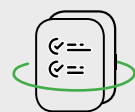

Supports wide range of clinical cases



**ICE**™

**A Classical Implant  
for Controlled Bone Penetration**

# ICE A Classical Implant for Controlled Bone Penetration



Diameter	Length	Ref. No.	Dimensions				
			A	B	C	D	H
 <b>Ø 3.7N</b>	10 mm	1000	Ø 3.75	Ø 2.2	Ø 1	Ø 3.5	2.5
	11.5 mm	1001	Ø 3.75	Ø 2.2	Ø 1	Ø 3.5	2.5
	13 mm	1003	Ø 3.75	Ø 2.2	Ø 1	Ø 3.5	2.5
 <b>Ø 3.75</b>	8 mm	1018	Ø 3.75	Ø 2.6	Ø 1.6	Ø 3.5	2.5
	10 mm	1010	Ø 3.75	Ø 2.6	Ø 1.6	Ø 3.5	2.5
	11.5 mm	1011	Ø 3.75	Ø 2.6	Ø 1.6	Ø 3.5	2.5
	13 mm	1013	Ø 3.75	Ø 2.6	Ø 1.6	Ø 3.5	2.5
	16 mm	1016	Ø 3.75	Ø 2.6	Ø 1.6	Ø 3.5	2.5
 <b>Ø 4.2</b>	6 mm	1056	Ø 4.2	Ø 2.7	Ø 2.7	Ø 3.5	2.5
	8 mm	1028	Ø 4.2	Ø 2.8	Ø 1.8	Ø 3.5	2.5
	10 mm	1020	Ø 4.2	Ø 2.8	Ø 1.8	Ø 3.5	2.5
	11.5 mm	1021	Ø 4.2	Ø 2.8	Ø 1.8	Ø 3.5	2.5
	13 mm	1023	Ø 4.2	Ø 2.8	Ø 1.8	Ø 3.5	2.5
	16 mm	1026	Ø 4.2	Ø 2.8	Ø 1.8	Ø 3.5	2.5
 <b>Ø 4.65</b>	6 mm	1036	Ø 4.65	Ø 2.9	Ø 2.9	Ø 3.5	2.5
	8 mm	1038	Ø 4.65	Ø 3	Ø 2	Ø 3.5	2.5
	10 mm	1030	Ø 4.65	Ø 3	Ø 2	Ø 3.5	2.5
	11.5 mm	1031	Ø 4.65	Ø 3	Ø 2	Ø 3.5	2.5
	13 mm	1033	Ø 4.65	Ø 3	Ø 2	Ø 3.5	2.5
 <b>Ø 5.3</b>	6 mm	1046	Ø 5.3	Ø 3.8	Ø 3.8	Ø 3.5	2.5
	8 mm	1048	Ø 5.3	Ø 3.45	Ø 2.45	Ø 3.5	2.5
	10 mm	1040	Ø 5.3	Ø 3.45	Ø 2.45	Ø 3.5	2.5
	11.5 mm	1041	Ø 5.3	Ø 3.45	Ø 2.45	Ø 3.5	2.5
	13 mm	1043	Ø 5.3	Ø 3.45	Ø 2.45	Ø 3.5	2.5

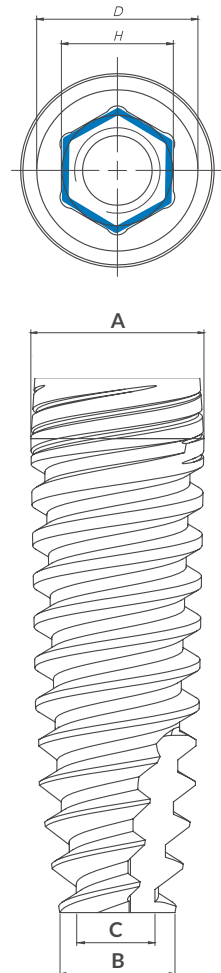

For **Internal Hex Connection (IH)** prosthetic solutions, see pages 86-103

# ICE A Classical Implant for Controlled Bone Penetration

## STEP DRILLING SEQUENCE

Ø 3.7N

Bone Type IV		Bone Type II & III			Bone Type I			
Ø2.0	Ø2.0/Ø2.4	Ø2.0	Ø2.4/Ø2.8	Ø2.8/Ø3.2	Ø2.0	Ø2.4/Ø2.8	Ø2.8/Ø3.2	Ø3.2/Ø3.65 Cortical*



Ø 3.75

Bone Type IV		Bone Type II & III			Bone Type I			
Ø2.0	Ø2.4/Ø2.8	Ø2.0	Ø2.4/Ø2.8	Ø2.8/Ø3.2	Ø2.0	Ø2.4/Ø2.8	Ø2.8/Ø3.2	Ø3.2/Ø3.65 Cortical*



Ø 4.2

Bone Type IV			Bone Type II & III			Bone Type I			
Ø2.0	Ø2.4/Ø2.8	Ø2.8/Ø3.2	Ø2.0	Ø2.4/Ø2.8	Ø3.2/Ø3.65	Ø2.0	Ø2.4/Ø2.8	Ø3.2/Ø3.65	Ø3.65/Ø4.1 Cortical*



Ø 4.65

Bone Type IV			Bone Type II & III				Bone Type I				
Ø2.0	Ø2.4 / Ø2.8	Ø3.2 / Ø3.65	Ø2.0	Ø2.4 / Ø2.8	Ø3.2 / Ø3.65	Ø3.65 / Ø4.1	Ø2.0	Ø2.4 / Ø2.8	Ø3.2 / Ø3.65	Ø3.65 / Ø4.1	Ø4.1 / Ø4.5 Cortical*



Ø 5.3

Bone Type IV				Bone Type II & III					Bone Type I					
Ø2.0	Ø2.4 / Ø2.8	Ø3.2 / Ø3.65	Ø3.65 / Ø4.1	Ø2.0	Ø2.4 / Ø2.8	Ø3.2 / Ø3.65	Ø3.65 / Ø4.1	Ø4.5 / Ø4.8	Ø2.0	Ø2.4 / Ø2.8	Ø3.2 / Ø3.65	Ø3.65 / Ø4.1	Ø4.5 / Ø4.8	Ø4.8 / Ø5.2 Cortical*

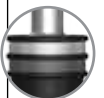

\* **Cortical** - Drill through cortical plate.



## STRAIGHT DRILLING SEQUENCE

Ø 3.7N

Bone Type IV		Bone Type II & III			Bone Type I			
Ø2.0	Ø2.4**	Ø2.0	Ø2.8	Ø3.2**	Ø2.0	Ø2.8	Ø3.2**	Ø3.65 Cortical*



Ø 3.75

Bone Type IV			Bone Type II & III			Bone Type I			
Ø2.0	Ø2.4	Ø2.8**	Ø2.0	Ø2.8	Ø3.2**	Ø2.0	Ø2.8	Ø3.2**	Ø3.65 Cortical*



Ø 4.2

Bone Type IV			Bone Type II & III				Bone Type I				
Ø2.0	Ø2.8	Ø3.2**	Ø2.0	Ø2.8	Ø3.2	Ø3.65**	Ø2.0	Ø2.8	Ø3.2	Ø3.65**	Ø4.1 Cortical*



Ø 4.65

Bone Type IV				Bone Type II & III				
Ø2.0	Ø2.8	Ø3.2	Ø3.65**	Ø2.0	Ø2.8	Ø3.2	Ø3.65	Ø4.1**

Bone Type I						
Ø2.0	Ø2.8	Ø3.2	Ø3.65	Ø4.1**	Ø4.5 Cortical*	



Ø 5.3

Bone Type IV					Bone Type II & III						
Ø2.0	Ø2.8	Ø3.2	Ø3.65	Ø4.1**	Ø2.0	Ø2.8	Ø3.2	Ø3.65	Ø4.1	Ø4.5	Ø4.8**

Bone Type I							
Ø2.0	Ø2.8	Ø3.2	Ø3.65	Ø4.1	Ø4.5	Ø4.8**	Ø5.2 Cortical*

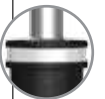

\* **Cortical** - Drill through cortical plate.

\*\* 3mm shorter than implant's length. Note that drill can be replaced by a corresponding step drill throughout entire implant's length. For more information, see step protocol.

**Important:** Professional discretion is advised for adaptations of the drilling sequence in different clinical cases.

# NICE™

## An Ultimate Solution for Narrow Ridges



The NICE implant is a moderately tapered  $\varnothing$  3.2 implant with a conical connection, suitable for implantation in narrow ridges & limited space.

A comprehensive Conical Narrow Connection prosthetic line is available for NICE implants:



 Conical Narrow Connection (CHC)

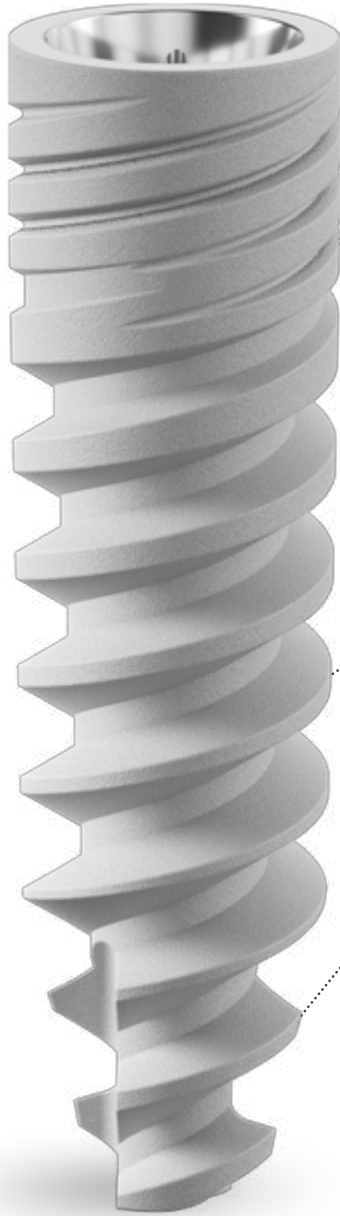

### MICRO THREADS

- Increased surface area
- Reduced marginal bone loss
- Immediate & long-term esthetic results

### MODERATELY TAPERED BODY AND CORE

- Smooth & controlled insertion

### TAPERED APEX WITH SHARP & DEEP THREADS

- Easy & controlled insertion
- High primary stability



Controlled bone penetration



Good primary stability



Improved stress distribution



Supports wide range of clinical cases

# NICE An Ultimate Solution for Narrow Ridges

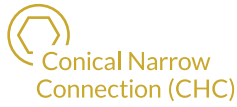



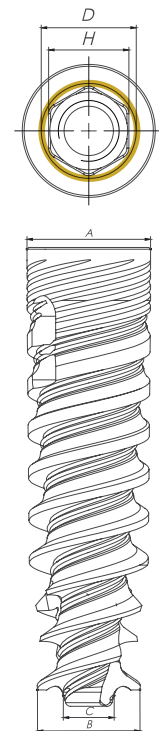



Diameter	Length	Ref. No	Dimensions				
			A	B	C	D	H
 <b>Ø 3.2</b>	8 mm	1068	Ø 3.2	Ø 2.2	Ø 1.1	Ø 2.5	2.1
	10 mm	1060	Ø 3.2	Ø 2.0	Ø 1.1	Ø 2.5	2.1
	11.5 mm	1061	Ø 3.2	Ø 2.0	Ø 1.1	Ø 2.5	2.1
	13 mm	1063	Ø 3.2	Ø 2.0	Ø 1.1	Ø 2.5	2.1
	16 mm	1066	Ø 3.2	Ø 2.0	Ø 1.1	Ø 2.5	2.1



For **Conical Narrow Connection (CHC)** prosthetic solutions, see pages 71-85

## STRAIGHT DRILLING SEQUENCE



Bone Type IV	Bone Type II & III			Bone Type I		
Ø2.0 	Ø2.0 	Ø2.8 	*	Ø2.0 	Ø2.8 	Ø3.0** 

\* In cases of thick cortical layer use 3.0 mm drill only through the cortex.

\*\* 3 mm shorter than implant's length.

**Important:** Professional discretion is advised for adaptations of the drilling sequence in different clinical cases.



# PROSTHETIC SOLUTIONS

**DURABILITY, FLEXIBILITY, PERFORMANCE  
& ESTHETICS**



**Alpha-Bio Tec. Implant-Abutment conical connections:**



**Conical Standard Connection**  
**CS**



**Conical Narrow Connection**  
**CHC**



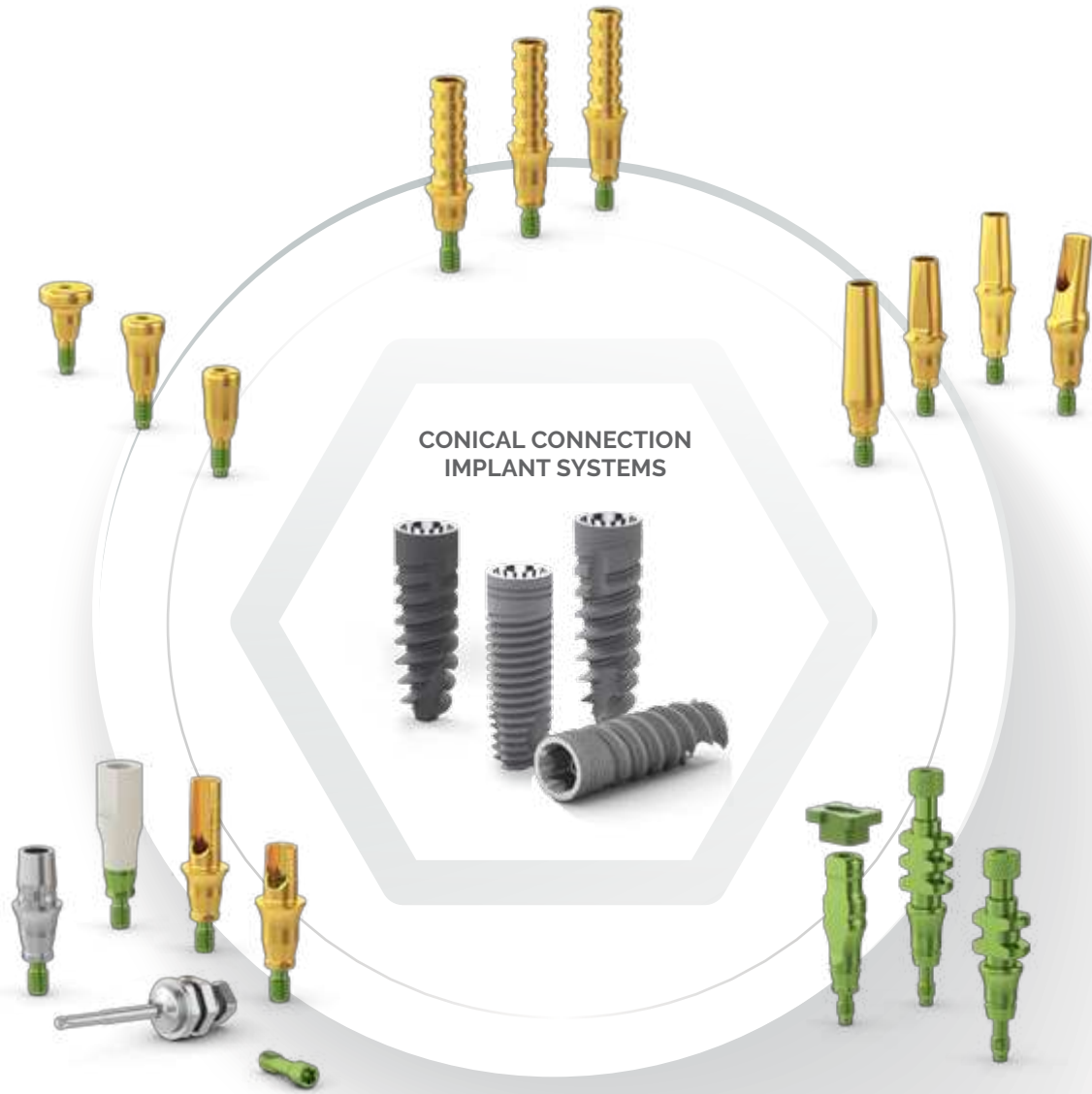

**END-TO-END CONICAL CONNECTION  
SOLUTION FOR PREDICTABLE  
AND ESTHETIC RESULTS**

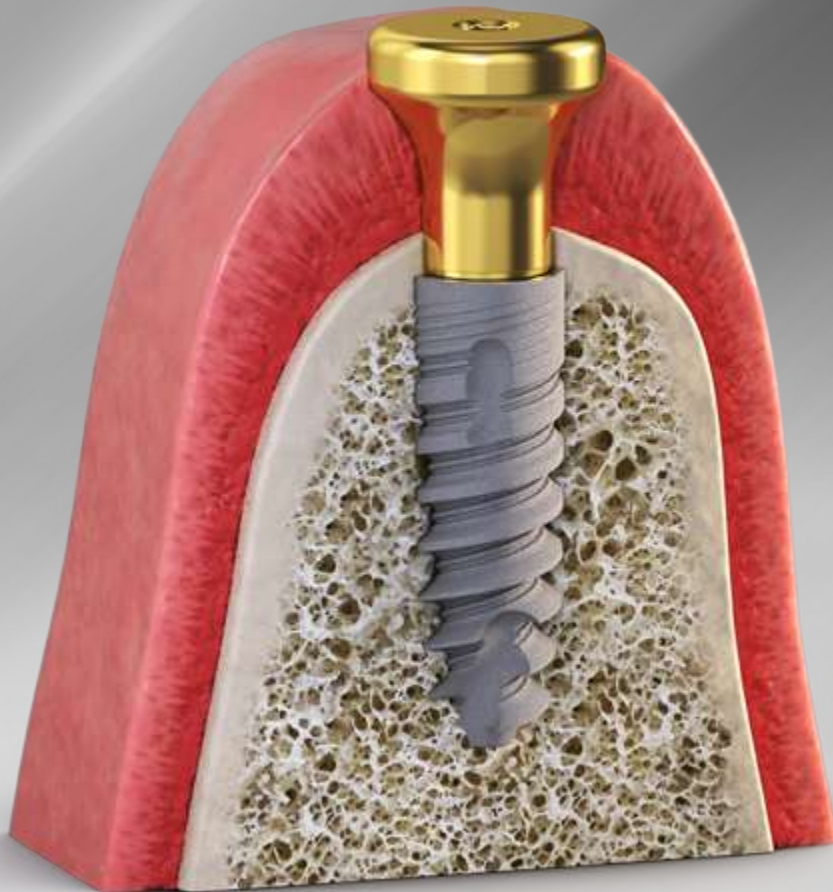

## PROSTHETIC SOLUTIONS ENGINEERED HARMONY, CONICAL SYNERGY

The ConiPro complete prosthetic system is designed for optimal soft tissue management & high esthetics. The system includes healing abutments, open and closed tray transfers, temporary & cement retained abutments & CAD/CAM components.



New concave emergence profile & gold anodization



A wide range of gingival heights with shared emergence profile



Designed for subcrestal implant placement



Comprehensive restoration process with high esthetic results





Conical Standard Connection  
**PROSTHETIC LINE**

**CS**



# HEALING ABUTMENTS

## DESIGN FEATURES

- New concave emergence profile
- Gold anodized
- A wide range of gingival heights
- Laser marking on top of the healing abutments (except for  $\varnothing 3.5$ ) to ensure easy identification of height and diameter



MANUAL  
TIGHTENING  
10 NCM



Code	HA-D3.5-1.5CS	HA-D3.5-2.5CS	HA-D3.5-3.5CS	HA-D3.5-4.5CS	HA-D3.5-5.5CS
Ref. No.	3931	3932	3933	3934	3935

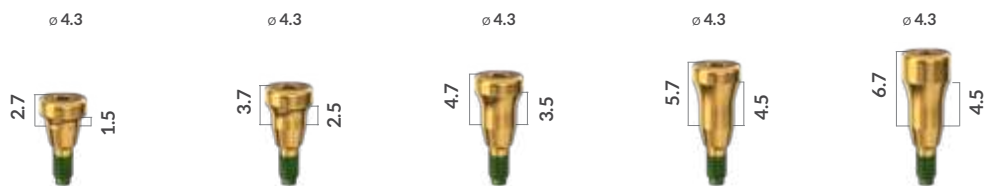

Code	HA-D4.3-1.5CS	HA-D4.3-2.5CS	HA-D4.3-3.5CS	HA-D4.3-4.5CS	HA-D4.3-5.5CS
Ref. No.	3941	3942	3943	3944	3945

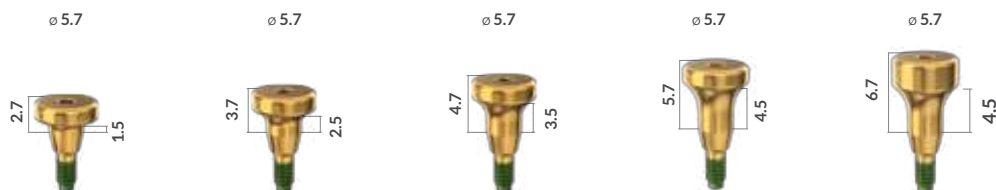

Code	HA-D5.7-1.5CS	HA-D5.7-2.5CS	HA-D5.7-3.5CS	HA-D5.7-4.5CS	HA-D5.7-5.5CS
Ref. No.	3951	3952	3953	3954	3955

### TECHNICAL INFORMATION:

**Material:** Titanium

**Recommended Tightening Torque:** Manual tightening

**Required Drivers:** 1.25mm prosthetic hex drivers (see page 114)

## DESIGN FEATURES

- New concave emergence profile
- New and improved design for ease of use
- Marking groove for accurate placement and positioning

### CLOSED TRAY TRANSFER

MANUAL TIGHTENING  
10 NCM

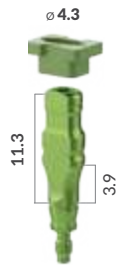

\* 10 units per package



Code	NSCTT-CS	TLACAP_10
Ref. No.	3961	3910

### OPEN TRAY TRANSFERS

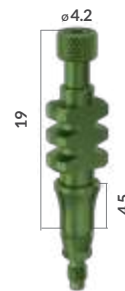

Code	LOTT-R-CS	SOTT-R-CS	LOTT-AR-CS	SOTT-AR-CS
Ref. No.	3963 ○	3964 ○	3965 ○	3966 ○

### ANALOG

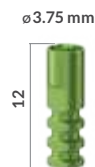

Code	IA-CS
Ref. No.	3459
Instructions	For plaster model

### TITANIUM SCREWS



Code	STLA-CS	RS
Ref. No.	3510	5110
Instructions	Replacement screw	Retrieval screw

### TECHNICAL INFORMATION:

**Material:** Titanium

**Recommended Tightening Torque:** Manual tightening

**Required Drivers:** 1.25mm prosthetic hex drivers (see page 114)

# TEMPORARY ABUTMENTS

## DESIGN FEATURES

- New concave emergence profile
- Deep grooves
- Gold anodized

30  
NCM

### NON-ENGAGED

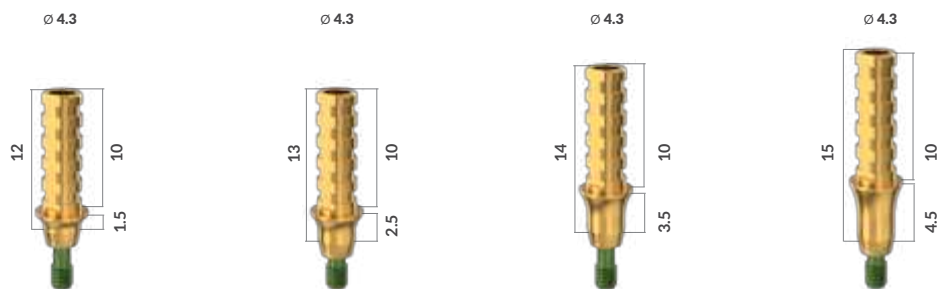

Code	TA-1.5-R-CS	TA-2.5-R-CS	TA-3.5-R-CS	TA-4.5-R-CS
Ref. No.	3901 ○	3902 ○	3903 ○	3904 ○

### ENGAGED

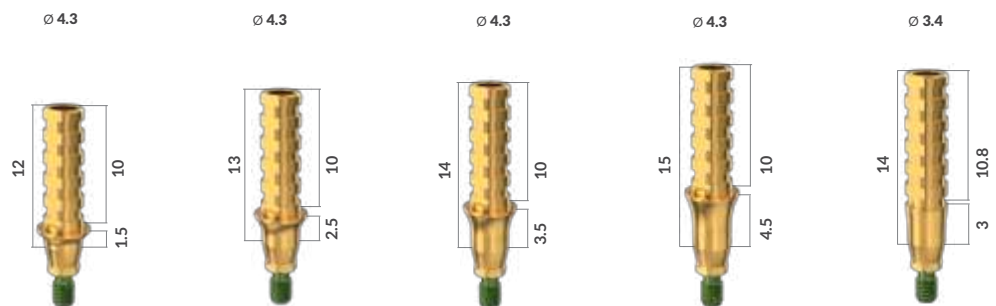

Code	TA-1.5-AR-CS	TA-2.5-AR-CS	TA-3.5-AR-CS	TA-4.5-AR-CS	TA-3N-R-CS
Ref. No.	3911 ○	3912 ○	3913 ○	3914 ○	3915 ○

## TECHNICAL INFORMATION:

**Material:** Titanium

**Recommended Tightening Torque:** 30NCM

**Required Drivers:** 1.25mm prosthetic hex drivers (see page 114)

## DESIGN FEATURES

- New concave emergence profile
- A range of gingival heights
- Gold anodized

## STRAIGHT ABUTMENTS

30 NCM

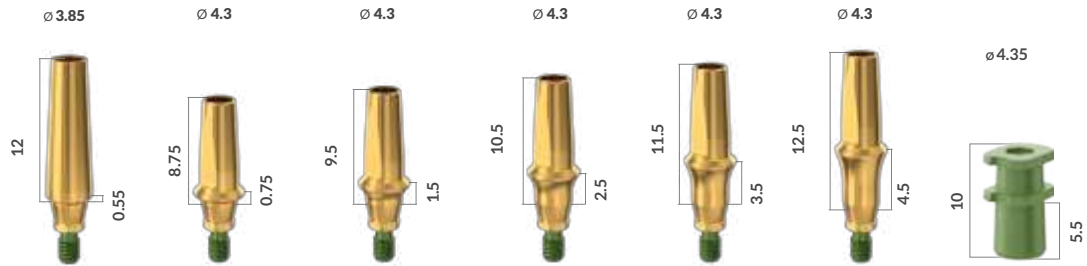

Code	TLA-L-CS	TLA-0.75-CS	TLA-1.5-CS	TLA-2.5-CS	TLA-3.5-CS	TLA-4.5-CS	TLASP_CS
Ref. No.	3926	3920	3921	3922	3923	3924	3925

\*The TLASP-CS plastic transfer is suitable for the following TLA-CS abutments: 3920, 3921, 3922, 3923, and 3924. For the abutment level impression workflow see page 92

## ANGLED ABUTMENTS

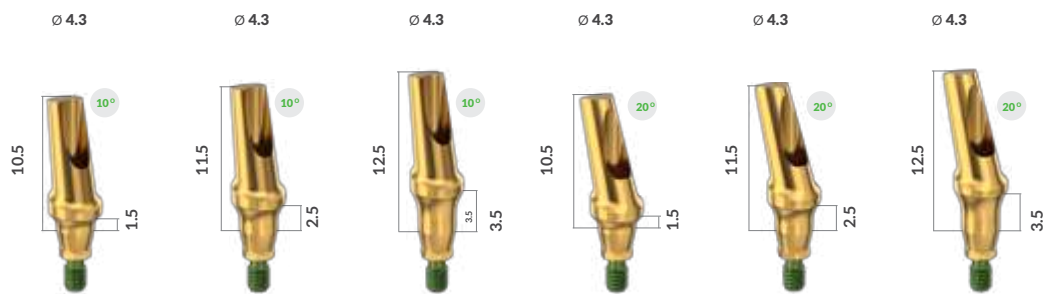

Code	NTLA10-H1.5CS	NTLA10-H2.5CS	NTLA10-H3.5CS	NTLA20-H1.5CS	NTLA20-H2.5CS	NTLA20-H3.5CS
Ref. No.	3971	3972	3973	3981	3982	3983

### TECHNICAL INFORMATION:

**Material:** Titanium

**Recommended Tightening Torque:** 30NCM

**Required Drivers:** 1.25mm prosthetic hex drivers (see page 114)

- For the abutment-level impression workflow, see page 91

# SCREW-RETAINED RESTORATIONS

30  
NCM

## Multi-Unit Abutment System

### STRAIGHT MULTI-UNIT ABUTMENTS

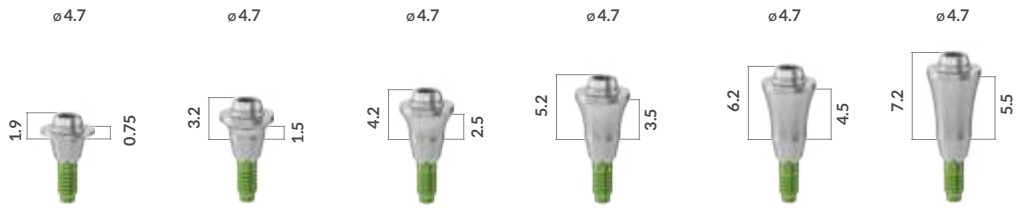

Code	TCT 0.75-CS	TCT 1.5-CS	TCT 2.5-CS	TCT 3.5-CS	TCT 4.5-CS	TCT 5.5-CS
Ref. No.	3870	3871	3872	3873	3874	3875

### ANGLED MULTI-UNIT ABUTMENTS

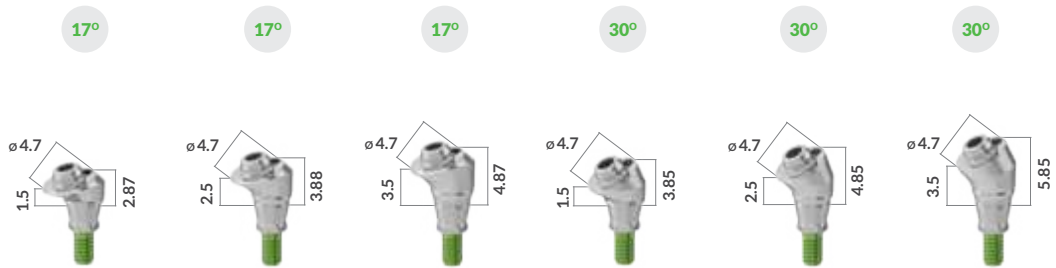

Code	AU17-1.5-CS	AU17-2.5-CS	AU17-3.5-CS	AU30-1.5-CS	AU30-2.5-CS	AU30-3.5-CS
Ref. No.	3862	3863	3864	3867	3868	3869

### HBC ABUTMENTS - FOR SINGLE IMPLANT RESTORATION



Code	HBC H0.75 CS	HBC H1.5 CS	HBC H2.5 CS
Ref. No.	3876	3877	3878

# SCREW-RETAINED RESTORATIONS



## On Top Components

### BURNOUT SLEEVES



### ANALOG



Code	PST-N-AR	PST-N	BTT-N
Ref. No.	5217 △	5218 ○	5211

\* Includes screw 6093

### OPEN TRAY TRANSFERS

MANUAL TIGHTENING 10 NCM

### CLOSED TRAY TRANSFER

### TEMPORARY ABUTMENT

20 NCM

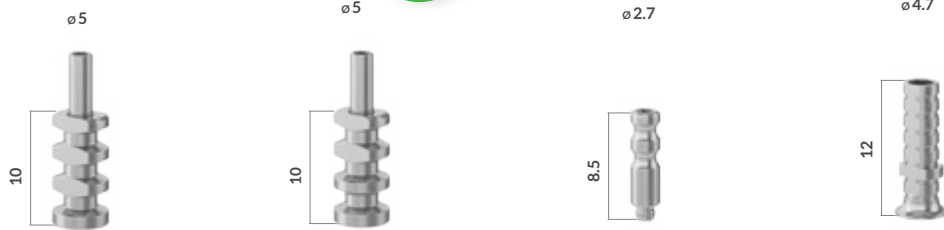

Code	TST-N	TST-N-R	TS-N	TTA-N
Ref. No.	5231 △	5248 ○	5235	5216*

\* Includes screw 6092

MANUAL TIGHTENING 10 NCM

### PRO HEALING ABUTMENTS

### SCREWS

20 NCM



Code	HCT4-N	HCT6-N	SF-N	SFT-N
Ref. No.	5236	5237	6092	6093**

\*\* Black coated screw for lab use

### TECHNICAL INFORMATION:

**Material:** Titanium

#### Recommended Tightening Torque:

- Manually tighten impression transfers & healing abutments
- 30 NCM for straight & angled CS Multi-Unit Abutments & HBC abutments
- 20 NCM for CS Temporary fixture & screws

#### Required Drivers: (see page 114):



- 1.25mm hex driver for angled multi-units abutments
- 1.5mm hex driver for straight multi-units abutments





# CAD/CAM RESTORATIONS



## MULTI-UNIT CAD/CAM COMPONENTS

MANUAL  
TIGHTENING  
10 NCM

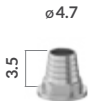
DUAL USE SCAN BODIES FOR MULTI-UNITS		ANALOG & INSERTION TOOL	
	ENGAGED	NON-ENGAGED	
			
Code	IOSB-TCT-N	IOSB-TCT-N-R	AN-PM-TCT-N
Ref. No.	5003 △	3883 ○	5456
Instructions	For single crown restorations with multi-unit angled abutments.	For bridge/bar restorations with multi-unit straight and angled abutments	Insertion tool for analog 3D printed model IH, CS, TCT

20  
NCM

ADHESIVE COPINGS FOR MULTI-UNITS		
	ENGAGED (For single tooth restorations)	NON-ENGAGED (For bar/bridge restorations)
		
Code	TAC-TCT-N	TAC-TCT-N-R
Ref. No.	5028 △	5029 ○
		AC-R-4.5
		5039 ○

TITANIUM SCREWS FOR MULTI-UNIT SYSTEM			
			
Code	SF-N	SFT-N	S-DM-SR
Ref. No.	6092	6093	4994
Instructions	Fixation screw for Multi-Unit restoration	Black coated screw for Lab	Direct mounting on metal frame. Should not be used for full zirconia or ceramic restorations

### TECHNICAL INFORMATION:

**Material:** Dual use scan body - PEEK and titanium | Adhesive copings, analogs & screws- titanium

**Recommended Tightening Torque:** Dual use scan body- manual tightening | Restoration cemented to adhesive coping, fixation screw, direct mounting screw- 20 NCM



	DUAL USE SCAN BODY	ANALOG	PRE-MILLED BLANKS	
	<p><b>MANUAL TIGHTENING</b> <b>10 NCM</b></p>			<p><b>30 NCM</b></p>
Code	IOSB-LCS	AN-PM-CS	BA-PF-CS	WBA-PF-CS
Ref. No.	3837	3838	3854	3855
Instructions	<ul style="list-style-type: none"> <li>For lab and/or intra-oral use</li> <li>Biocompatible &amp; reusable</li> </ul>	For 3D printed model	For Preface® abutment holder. Screw included	

## TI-BASES

**30 NCM**

	ENGAGED (For single tooth restorations)			NON-ENGAGED (For bar/bridge restorations)		
Code	TB-0.75-AR-CS	TB-1.5-AR-CS	TB-2.5-AR-CS	TB-0.75-R-CS	TB-1.5-R-CS	TB-2.5-R-CS
Ref. No.	3832 ◻	3840 ◻	3842 ◻	3833 ○	3841 ○	3843 ○

TI-BASES suitable for use with CEREC System (Sirona's L Blocks), 3shape and exocad software

Code	CSTB-CS-SI	SiTB_CS_1.5	SiTB_CS_2.5	SiTB_CS_3.5	CSSP-CS-SI
Ref. No.	3856	5470	5471	5472	3857
Instructions	For scan and/or restoration use				For scanning only with CEREC system

### TECHNICAL INFORMATION:

**Material:** Dual use scan body - PEEK and titanium | Ti-Bases - titanium

**Recommended Tightening Torque:** Dual use scan body - manual tightening | Ti-bases and Pre-milled blanks - 30 NCM

**Required Drivers:** 1.25mm prosthetic hex drivers (see page 114) | For analog Ref. No. 3838, use insertion tool Ref. No. 5459

# OMNIBASE

## Experience Freedom: Flexibility & Esthetics from a New Angle

The Omnibase is a Ti-Base used in CAD/CAM screw-retained restorations, enabling the dental technician the flexibility to design a restoration with a screw access channel at a favorable position & angle (0°-25°), contributing to improved esthetics, greater accessibility in the anterior region & in limited occlusal spaces. Available for standard and narrow conical implant-abutment connections (CS & CHC) in a wide range of gingival heights.

The Omnibase Ti-Bases have a narrow (ø 4.3mm) concave emergence profile & are suitable for cases of subcrestal implant placement.



### DESIGN FEATURES & CLINICAL BENEFITS

- Standard & customizable Ti-bases
- A wide range of gingival heights
- Retrievable screw for ease of use & maintenance
- Gold anodized
- High esthetic results

30  
NCM

### STANDARD OMNIBASES

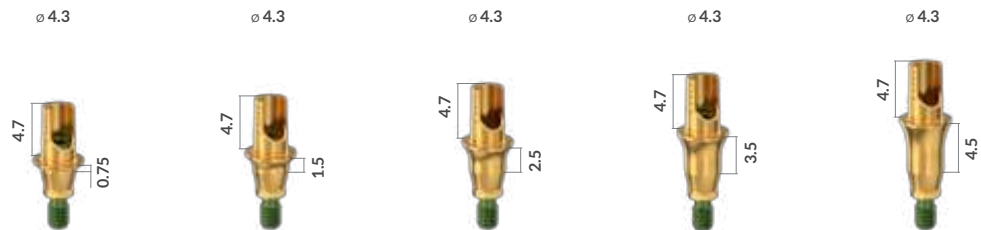

Code	OB4.7-0.75-CS	OB4.7-1.5-CS	OB4.7-2.5-CS	OB4.7-3.5-CS	OB4.7-4.5-CS
Ref. No.	5490	5491	5492	5493	5494

### CUSTOMIZABLE OMNIBASES

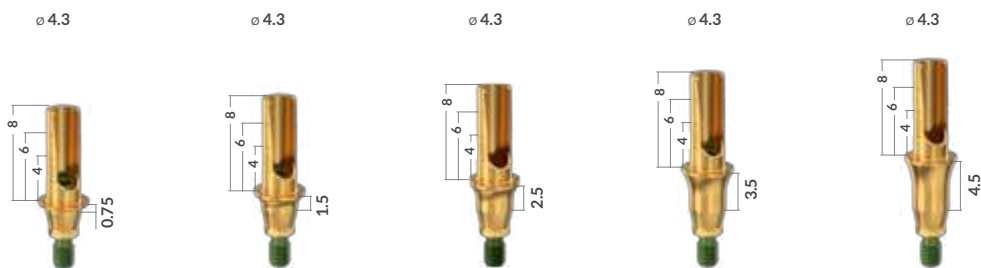

Code	OB8-0.75-CS	OB8-1.5-CS	OB8-2.5-CS	OB8-3.5-CS	OB8-4.5-CS
Ref. No.	5480	5481	5482	5483	5484

Experience Freedom: Flexibility & Esthetics from a New Angle

## TX SCREWS

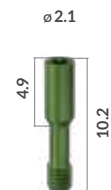

Code	OB-TX-S-CS	OB-TX-L-CS
Ref. No.	5485	5486

The Omnibase product package contains a Ti-Base and a TX screw (TX screws are also sold separately for replacement purposes).

### TECHNICAL INFORMATION:

**Material:** Titanium

**Recommended Tightening Torque:** 30 NCM

**Required Drivers:**

TX Drivers for CS & CHC TX screws / Omnibases, for tightening at 0°-25° (See TX drivers on page 116-117)









FOR THE OMNIBASE INSTRUCTIONAL GUIDE STEP BY STEP, SCAN THE QR CODE.



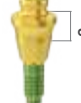



# OVERDENTURE RESTORATIONS

## ALPHALOC ABUTMENT SYSTEM







ALPHALOC KIT						
	$\varnothing 3.1$	$\varnothing 3.9$	$\varnothing 3.9$	$\varnothing 3.9$	$\varnothing 3.9$	
						
	0.75	2	3	4	5	
	Code	AK-0.75 - CS	AK-1.5 - CS	AK-2.5 - CS	AK-3.5 - CS	AK-4.5 - CS
	Ref. No.	3710	3711	3712	3713	3714

Each AlphaLoc kit includes :

AlphaLoc abutment (of the selected gingival height), 1 stainless steel metal housing, 4 retentive caps, 1 block-out spacer, 1 laboratory cap

ALPHALOC PROCESSING PACKAGE		ALPHALOC RETENTIVE CAPS			
					
Code	AMPP	AMSTR	AMSTA	AMSOF	AMESO
Ref. No.	4875	4876	4877	4878	4879
Includes	Stainless steel metal housing, block-out spacer, nylon retentive caps (violet, clear, pink and yellow), laboratory cap (black)	Violet (strong retention)	Clear (standard retention)	Pink (soft retention)	Yellow (extra soft retention)
	Each package contains 4 units of the same colored retentive caps				

## ALPHALOC ACCESSORIES

	LABORATORY CAP (BLACK)	BLOCK OUT SPACER	IMPRESSION COPING	MALE ANALOG	INSERTION TOOL *	EXTRACTION TOOL *
						
Content	4 Units	1 Unit	4 Units	4 Units	1 Unit	1 Unit
Code	AML	ABOS	AIC	AFA	AIT	AET
Ref. No.	4882	4883	4884	4885	4886*	4887*

\* In some markets, a dual-tip single instrument (for cap insertion and extraction) is available for order

Legacy Prosthetic Line for Conical Standard (CS) Connection

## CLASSIC CS HEALING ABUTMENT

MANUAL TIGHTENING  
10 NCM

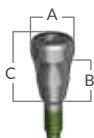

Ref. No.	Code	Dimensions
3401	HA-D4-CH1.5-CS	A: Ø 4.0 mm, B: 1.5 mm, C: 3 mm
3402	HA-D4-CH2.5-CS	A: Ø 4.0 mm, B: 2.5 mm, C: 4 mm
3403	HA-D4-CH3.5-CS	A: Ø 4.0 mm, B: 3.5 mm, C: 5 mm
3404	HA-D4-CH4.5-CS	A: Ø 4.0 mm, B: 4.5 mm, C: 6 mm
3405	HA-D4-CH5.5-CS	A: Ø 4.0 mm, B: 5.5 mm, C: 7 mm
3407	HA-4.9-1.5-CS	A: Ø 4.9 mm, B: 1.5 mm, C: 3 mm
3408	HA-4.9-2.5-CS	A: Ø 4.9 mm, B: 2.5 mm, C: 4 mm
3409	HA-4.9-3.5-CS	A: Ø 4.9 mm, B: 3.5 mm, C: 5 mm
3410	HA-4.9-4.5-CS	A: Ø 4.9 mm, B: 4.5 mm, C: 6 mm
3411	HA-4.9-5.5-CS	A: Ø 4.9 mm, B: 5.5 mm, C: 7 mm
3412	HA-D6.2-CH1.5-CS	A: Ø 6.2 mm, B: 1.5 mm, C: 3 mm
3413	HA-D6.2-CH2.5-CS	A: Ø 6.2 mm, B: 2.5 mm, C: 4 mm

## CLASSIC CS IMPLANT IMPRESSION

MANUAL TIGHTENING  
10 NCM

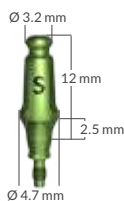

### SHORT CLOSED TRAY TRANSFER

REF. NO.	Code
3450	SCTT-CS

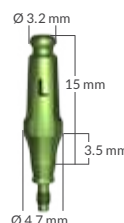

### LONG OPEN TRAY TRANSFER

REF. NO.	Code
3451	LCTT-CS

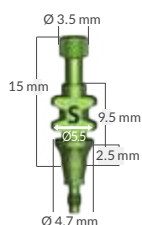

### SHORT OPEN TRAY TRANSFER

REF. NO.	Code
3455	SOTT-CS

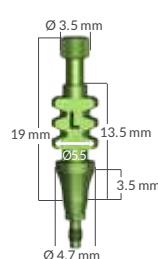

### LONG CLOSED TRAY TRANSFER

REF. NO.	Code
3456	LOTT-CS

# CLASSIC CS PROSTHETICS

Legacy Prosthetic Line for Conical Standard (CS) Connection

## CLASSIC CS CEMENT RETAINED RESTORATIONS

30  
NCM

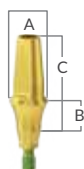

### STRAIGHT ABUTMENT

Ref. No.	Code	Dimensions
3501	TLA-H1.5CS	A: Ø 4.8 mm, B: 1.5 mm, C: 9.5 mm
3502	TLA-H2.5CS	A: Ø 4.8 mm, B: 2.5 mm, C: 10.5 mm
3503	TLA-H3.5CS	A: Ø 4.8 mm, B: 3.5 mm, C: 11.5 mm
3504	TLA-H4.5CS	A: Ø 4.8 mm, B: 4.5 mm, C: 12.5 mm



### SIMPLY CLOSE TRAY PLASTIC TRANSFER

5364	HTLASP	For use with abutments 3501, 3502, 3503, 3504
------	--------	---

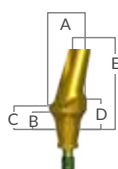

### ANGLED ABUTMENT

3511	TLA15°H1.5CS	A: Ø 4.8 mm, B: 1.5 mm, C: 2 mm, D: 3 mm, E: 10.5 mm
3512	TLA15°H2.5CS	A: Ø 4.8 mm, B: 2.5 mm, C: 3 mm, D: 4 mm, E: 11.5 mm
3514	TLA25°H1.5CS	A: Ø 4.8 mm, B: 1.5 mm, C: 2 mm, D: 3 mm, E: 10.5 mm
3515	TLA25°H2.5CS	A: Ø 4.8 mm, B: 2.5 mm, C: 3 mm, D: 4 mm, E: 11.5 mm

## CLASSIC CS TEMPORARY ABUTMENTS

30  
NCM

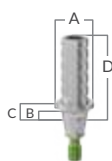

Ref. No.	Code	Dimensions
3532	TA-AR-CS	A: Ø 4.7 mm, B: 1.5 mm, C: 2 mm, D: 10 mm
3533	TA-R-CS	A: Ø 4.7 mm, B: 1.5 mm, C: 2 mm, D: 10 mm

### TECHNICAL INFORMATION:

**Material:** Titanium

**Recommended Tightening Torque:**

- Manually tighten healing abutments, transfers & analogs
- 30 NCM for straight, angled & temporary abutments

**Required Drivers:**

1.25mm prosthetic hex drivers (see page 114)



Conical Narrow Connection  
**PROSTHETIC LINE**

**CHC**



# HEALING ABUTMENTS

## DESIGN FEATURES

- New narrow concave emergence profile
- Gold anodized
- A wide range of gingival heights
- Laser marking on top of the healing abutments (except for  $\varnothing 2.7$ ) to ensure easy identification of height and diameter



MANUAL  
TIGHTENING  
10 NCM

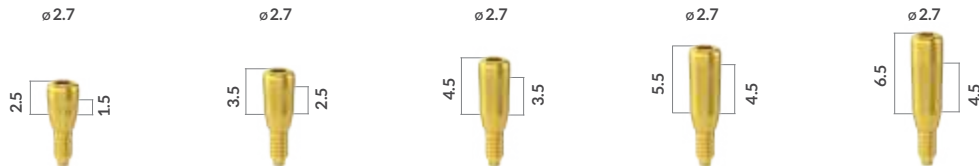

Code	HA-D2.7-1.5CHC	HA-D2.7-2.5CHC	HA-D2.7-3.5CHC	HA-D2.7-4.5CHC	HA-D2.7-5.5CHC
Ref. No.	3351	3352	3353	3354	3355



Code	HA-D3.8-1.5CHC	HA-D3.8-2.5CHC	HA-D3.8-3.5CHC	HA-D3.8-4.5CHC	HA-D3.8-5.5CHC
Ref. No.	3361	3362	3363	3364	3365



Code	HA-D4.2-1.5CHC	HA-D4.2-2.5CHC	HA-D4.2-3.5CHC	HA-D4.2-4.5CHC	HA-D4.2-5.5CHC
Ref. No.	3341	3342	3343	3344	3345

### TECHNICAL INFORMATION:

**Material:** Titanium

**Recommended Tightening Torque:** Manual tightening

**Required Drivers:** 1.25mm prosthetic hex drivers (see page 114)



## DESIGN FEATURES

- New Narrow Concave emergence profile
- New and improved design for ease of use
- Marking groove for accurate placement and positioning

MANUAL  
TIGHTENING  
10 NCM

## IMPLANT IMPRESSION

	CLOSED TRAY TRANSFER	OPEN TRAY TRANSFERS		
Code	NCTT-CHC	SOTT-R-CHC	SOTT-AR-CHC	LOTT-AR-CHC
Ref. No.	3350	3306	3308	3307

- Screw is included
- Ref. No. 3350 is supplied with a snap cap (as shown on page 59)

## IMPLANT ANALOGS

Code	IA-CHC	BTT-N
Ref. No.	7338	5211
Instructions	For Multi-Unit restorations	

## TITANIUM SCREWS

	PROSTHETIC SCREW CHC	RETRIEVAL SCREW CHC
Code	STLA_CHC_60_DEG	RS-CHC
Ref. No.	5463	7400

## TECHNICAL INFORMATION:

Material: Titanium

Recommended Tightening Torque: Manual tightening

Required Drivers: 1.25mm prosthetic hex drivers  
(see page 114)

# TEMPORARY ABUTMENTS

## DESIGN FEATURES

- New narrow concave emergence profile
- Gold anodized
- Deep grooves

20  
NCM

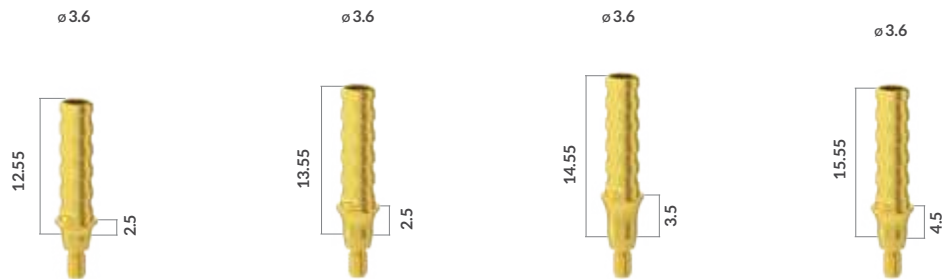

Code	TA-1.5-R-CHC	TA-2.5-R-CHC	TA-3.5-R-CHC	TA-4.5-R-CHC
Ref. No.	3301 ○	3302 ○	3303 ○	3304 ○



Code	TA-1.5-AR-CHC	TA-2.5-AR-CHC	TA-3.5-AR-CHC	TA-4.5-AR-CHC	TA-3N-AR-CHC
Ref. No.	3311 ○	3312 ○	3313 ○	3314 ○	3309 ○



### TECHNICAL INFORMATION:

**Material:** Titanium

**Recommended Tightening Torque:** 20NCM

**Required Drivers:** 1.25mm prosthetic hex drivers (see page 114)

## DESIGN FEATURES

- New narrow concave emergence profile
- Gold anodized
- A range of gingival heights

## STRAIGHT ABUTMENTS

20  
NCM

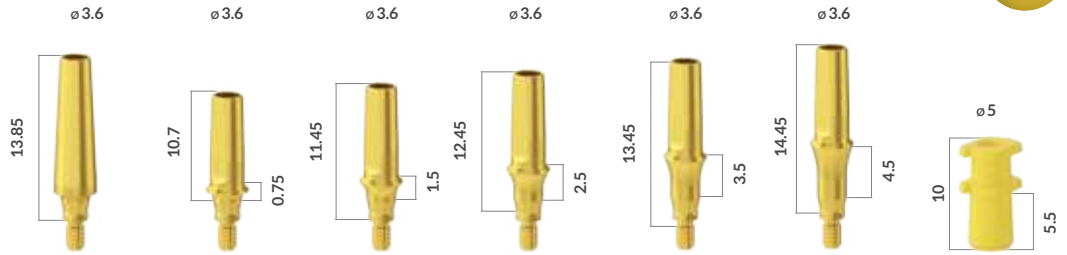

Code	TLA-L-CHC	TLA-0.75-CHC	TLA-1.5-CHC	TLA-2.5-CHC	TLA-3.5-CHC	TLA-4.5-CHC	TLASP-CHC*
Ref. No.	3315	3320	3321	3322	3323	3324	3327

\*The TLASP-CHC plastic transfer is suitable for the following TLA-CHC abutments: 3320, 3321, 2211, 3323, and 3324. For the abutment level impression workflow see page 92

## ANGLED ABUTMENTS

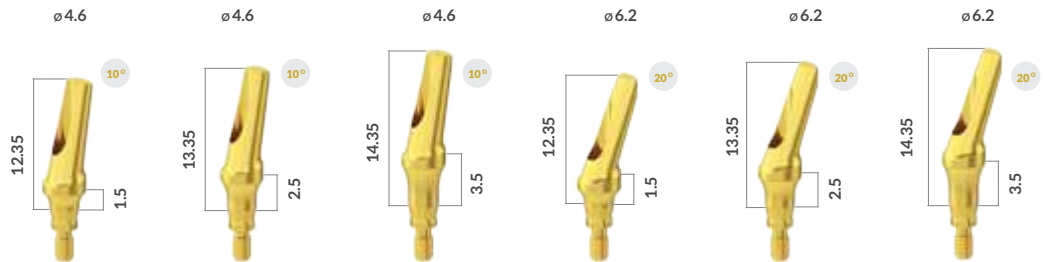

Code	NTLA10_H1.5-CHC	NTLA10_H2.5-CHC	NTLA10_H3.5-CHC	NTLA20-H1.5-CHC	NTLA20-H2.5-CHC	NTLA20-H3.5-CHC
Ref. No.	3381	3382	3383	3371	3372	3373



### TECHNICAL INFORMATION:

**Material:** Titanium

**Recommended Tightening Torque:** 20NCM

**Required Drivers:** 1.25mm prosthetic hex drivers (see page 114)

- For the abutment-level impression workflow, see page 91

# SCREW-RETAINED RESTORATIONS

Multi-Unit Abutment System

20  
NCM

## STRAIGHT MULTI-UNIT ABUTMENTS

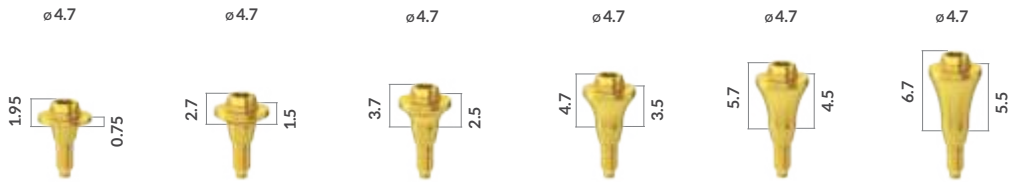

Code	TCT-N 0.75 CHC	TCT-N 1.5 CHC	TCT-N 2.5 CHC	TCT-N 3.5 CHC	TCT-N 4.5 CHC	TCT-N 5.5 CHC
Ref. No.	5242	5243	5244	5245	5246	5247

## ANGLED MULTI-UNIT ABUTMENTS

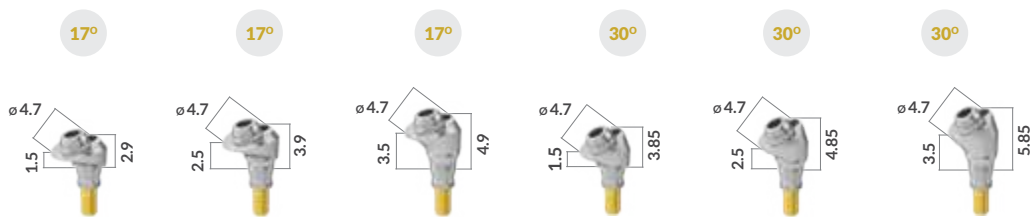

Code	AU 17-1.5 CHC	AU 17-2.5 CHC	AU 17-3.5 CHC	AU 30-1.5 CHC	AU 30-2.5 CHC	AU 30-3.5 CHC
Ref. No.	7482	7483	7484	7487	7488	7489



## On Top Components

### BURNOUT SLEEVES



### ANALOG

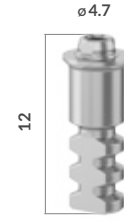

Code	PST-N-AR	PST-N	BTT-N
Ref. No.	5217 $\triangle$	5218 $\circ$	5211

\* Includes screw 6093

### OPEN TRAY TRANSFERS

MANUAL TIGHTENING 10 NCM

### CLOSED TRAY TRANSFER

### TEMPORARY ABUTMENT

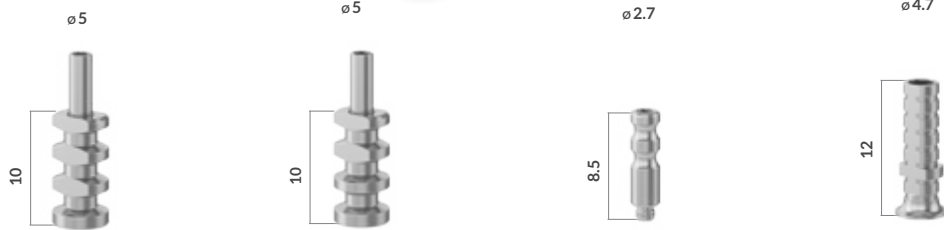

20 NCM

Code	TST-N	TST-N-R	TS-N	TTA-N
Ref. No.	5231 $\triangle$	5248 $\circ$	5235	5216*

\* Includes screw 6092

MANUAL TIGHTENING 10 NCM

### PRO HEALING ABUTMENTS

### SCREWS



20 NCM

Code	HCT4-N	HCT6-N	SF-N	SFT-N
Ref. No.	5236	5237	6092	6093**

\*\* Black coated screw for lab use

### TECHNICAL INFORMATION:

**Material:** Titanium

#### Recommended Tightening Torque:

- Manually tighten impression transfers & healing abutments
- 20 NCM for straight & angled CHC Multi-Unit Abutments
- 20 NCM for CHC Temporary fixture & screws

#### Required Drivers (see page 114):





- 1.25mm prosthetic hex drivers for multi-unit angled abutments
- 1.5mm prosthetic hex drivers for multi-unit straight abutments



# CAD/CAM RESTORATIONS



MANUAL  
TIGHTENING  
10 NCM

## MULTI-UNIT CAD/CAM COMPONENTS

DUAL USE SCAN BODIES FOR MULTI-UNITS			ANALOG & INSERSION TOOL	
	ENGAGED	NON-ENGAGED		
				
Code	IOSB-TCT-N	IOSB-TCT-N-R	AN-PM-TCT-N	APMT_IH_CS
Ref. No.	5003 △	3883 ○	5456	5459
Instructions	For single crown restorations with multi-unit angled abutments.	For bridge/bar restorations with multi-unit straight and angled abutments	Multi-Unit/TCT analog for 3D printed model	Insertion tool for analog 3D printed model IH, CS, TCT

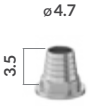
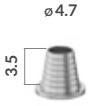

20  
NCM

## ADHESIVE COPINGS FOR MULTI-UNITS

	ENGAGED (For single tooth restorations)	NON-ENGAGED (For bar/bridge restorations)	
			
Code	TAC-TCT-N	TAC-TCT-N-R	AC-R-4.5
Ref. No.	5028 △	5029 ○	5039 ○

\* Black coated screw for lab for lab use

## TITANIUM SCREWS FOR MULTI-UNIT SYSTEM

			
Code	SF-N	SFT-N	S-DM-SR
Ref. No.	6092	6093	4994
Instructions	Fixation screw for Multi-Unit restoration	Black coated screw for Lab	Direct mounting on metal frame. Should not be used for full zirconia or ceramic restorations

### TECHNICAL INFORMATION:

**Material:** Dual use scan body - PEEK and titanium | Adhesive copings, analogs & screws- titanium

**Recommended Tightening Torque:** Dual use scan body- manual tightening | Restoration cemented to adhesive coping, fixation screw, direct mounting screw- 20 NCM

DUAL USE SCAN BODY		ANALOG & INSERTION TOOL		PRE-MILLED BLANK
Code	SB-CHC	AN-PM-CHC	APMT_CHC	BA-PF-CHC
Ref. No.	5021	5458	5460	4990
Instructions	<ul style="list-style-type: none"> <li>For lab and/or intra-oral use</li> <li>Biocompatible &amp; reusable</li> </ul>	CHC analog for 3D printed model	Insertion tool for 3D printed model CHC	For Preface® abutment holder

## TI-BASES

20 NCM

ENGAGED (For single tooth restorations)			NON-ENGAGED (For bar/bridge restorations)			
Code	CCTB-0.75-AR-CHC	CCTB-1.5-AR-CHC	CCTB-2.5-AR-CHC	CCTB-0.75-R-CHC	CCTB-1.5-R-CHC	CCTB-2.5-R-CHC
Ref. No.	5450 ◻	5451 ◻	5452 ◻	5453 ○	5454 ○	5455 ○

## TI-BASES suitable for use with CEREC System (Sirona's L Blocks), 3shape and exocad software

Code	CCTB-CHC-SI	SiTB_CHC_1.5	SiTB_CHC_2.5	SiTB_CHC_3.5	CCSP-CHC-SI
Ref. No.	4982	5467	5468	5469	4985
Instructions	For scan and/or restoration use <ul style="list-style-type: none"> <li>Use replacement screw Ref. No. 7345 for Ti-Base Ref. No. 4982.</li> <li>Use replacement screw Ref. No. 5463 for Ti-Bases Ref. No. 5467, 5468 &amp; 5469.</li> </ul>				For scanning only with CEREC system

### TECHNICAL INFORMATION:

**Material:** Dual use scan body - PEEK and titanium | Ti-Bases - titanium

**Recommended Tightening Torque:** Dual use scan body - manual tightening | Ti-bases and Pre-milled blanks - 20 NCM

**Required Drivers:** 1.25mm prosthetic hex drivers (see page 114)

# OMNIBASE

## Experience Freedom: Flexibility & Esthetics from a New Angle

The Omnibase is a Ti-Base used in CAD/CAM screw-retained restorations, enabling the dental technician the flexibility to design a restoration with a screw access channel at a favorable position & angle (0°-25°), contributing to improved esthetics, greater accessibility in the anterior region & in limited occlusal spaces. Available for standard and narrow conical implant-abutment connections (CS & CHC) in a wide range of gingival heights.

The Omnibase Ti-Bases have a narrow (ø 3.8mm) concave emergence profile & are suitable for cases of subcrestal implant placement.



### DESIGN FEATURES & CLINICAL BENEFITS

- Standard & customizable Ti-bases
- A wide range of gingival heights
- Retrievable screw for ease of use & maintenance
- Gold anodized
- High esthetic results

20  
NCM

### STANDARD OMNIBASES

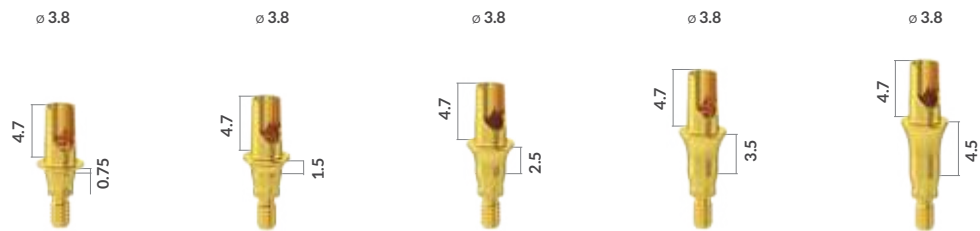

Code	OB4.7-0.75-CHC	OB4.7-1.5-CHC	OB4.7-2.5-CHC	OB4.7-3.5-CHC	OB4.7-4.5-CHC
Ref. No.	5530	5531	5532	5533	5534

### CUSTOMIZABLE OMNIBASES

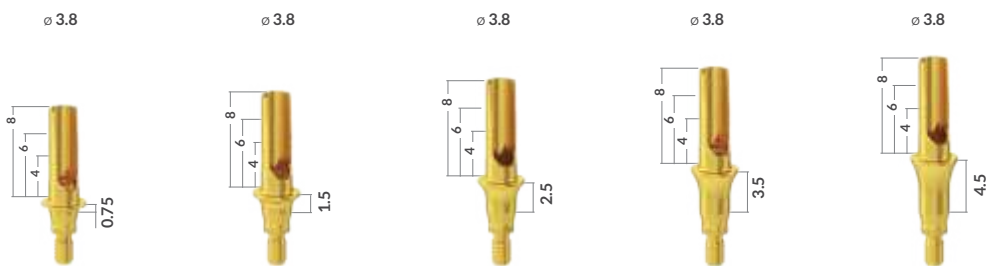

Code	OB8-0.75-CHC	OB8-1.5-CHC	OB8-2.5-CHC	OB8-3.5-CHC	OB8-4.5-CHC
Ref. No.	5540	5541	5542	5543	5544



Experience Freedom: Flexibility & Esthetics from a New Angle

## TX SCREWS

∅1.9



∅1.9



Code	OB-TX-S-CHC	OB-TX-L-CHC
Ref. No.	5507	5501

The Omnibase product package contains a Ti-Base and a TX screw (TX screws are also sold separately for replacement purposes).

### TECHNICAL INFORMATION:

**Material:** Titanium

**Recommended Tightening Torque:** 20 NCM

#### Required Drivers:

TX Drivers for CS & CHC TX screws / Omnibases, for tightening at 0°-25° (See TX drivers on page 116-117)

FOR THE OMNIBASE INSTRUCTIONAL GUIDE STEP BY STEP, SCAN THE QR CODE.



# OVERDENTURE RESTORATIONS

## ALPHALOC ABUTMENT SYSTEM

20  
NCM

### ALPHALOC KIT

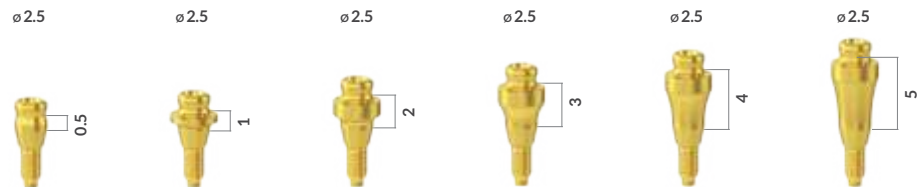

Code	AK0.5-C-CHC	AK1-C-CHC	AK2-C-CHC	AK3-C-CHC	AK4-C-CHC	AK5-C-CHC
Ref. No.	7470	7471	7472	7473	7474	7475

Each AlphaLoc kit includes :

AlphaLoc abutment (of the selected gingival height), 1 stainless steel metal housing, 4 retentive caps, 1 block-out spacer, 1 laboratory cap 1

### ALPHALOC PROCESSING PACKAGE



### ALPHALOC RETENTIVE CAPS



Code	AMPP	AMSTR	AMSTA	AMSOF	AMESO
Ref. No.	4875	4876	4877	4878	4879
Includes	Stainless steel metal housing, block-out spacer, nylon retentive caps (violet, clear, pink and yellow), laboratory cap (black)	Violet (strong retention)	Clear (standard retention)	Pink (soft retention)	Yellow (extra soft retention)
Each package contains 4 units of the same colored retentive caps					

## ALPHALOC ACCESSORIES

LABORATORY CAP  
(BLACK)

BLOCK OUT  
SPACER

IMPRESSION  
COPING

MALE  
ANALOG

INSERTION  
TOOL \*

EXTRACTION  
TOOL \*



Content	4 Units	1 Unit	4 Units	4 Units	1 Unit	1 Unit
Code	AML	ABOS	AIC	AFA	AIT	AET
Ref. No.	4882	4883	4884	4885	4886*	4887*

\* In some markets, the insertion and extraction tool is provided as a single, dual sided instrument.





20  
NCM

## STRAIGHT BALL ATTACHMENTS



Code	TB1-CHC	TB2-CHC	TB3-CHC	TB4-CHC	TB5-CHC
Ref. No.	7403	7404	7405	7406	7407
Instructions	Use 1.25 driver for insertion. Use nylon cap $\varnothing$ 2.5 mm.				

## NYLON CAP FOR $\varnothing$ 2.5 MM

	Stainless steel Housing	Nylon Cap	Nylon Cap with Titanium Ring	Soft Nylon Cap
				
Code	H	NC	NCT	NCA
Ref. No.	6240	6250	6251	6253



# CLASSIC CHC PROSTHETICS

Legacy Prosthetic Line for Conical Narrow (CHC) Connection

## CLASSIC CHC HEALING ABUTMEN

MANUAL  
TIGHTENING  
10 NCM

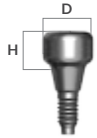

REF. NO.	Code	Dimensions
7311	HSD3.4-2-CHC	D: Ø 3.4 mm, H: 2 mm
7312	HSD3.4-3-CHC	D: Ø 3.4 mm, H: 3 mm
7313	HSD3.4-5-CHC	D: Ø 3.4 mm, H: 5 mm
7315	HSD3.8-2-CHC	D: Ø 3.8 mm, H: 2 mm
7316	HSD3.8-3-CHC	D: Ø 3.8 mm, H: 3 mm
7317	HSD3.8-5-CHC	D: Ø 3.8 mm, H: 5 mm
7319	HSD4.2-2-CHC	D: Ø 4.2 mm, H: 2 mm
7320	HSD4.2-3-CHC	D: Ø 4.2 mm, H: 3 mm
7321	HSD4.2-5-CHC	D: Ø 4.2 mm, H: 5 mm

MANUAL  
TIGHTENING  
10 NCM

## CLASSIC IMPLANT IMPRESSION

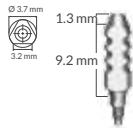

### CLOSED TRAY TRANSFER

REF. NO.	Code
7333	HLTS-CHC

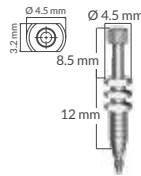

### OPEN TRAY TRANSFER

REF. NO.	Code
7335	HLTO-CHC

20  
NCM

## CLASSIC CEMENT RETAINED RESTORATION

### STRAIGHT ABUTMENTS

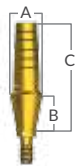

REF. NO.	Code	Dimensions
7350	ETLASP1-CHC	A: Ø 3.6 mm, B: 1.0 mm, C: 8.9 mm
7351	ETLASP2-CHC	A: Ø 3.6 mm, B: 2.0 mm, C: 9.9 mm
7352	ETLASP3-CHC	A: Ø 3.6 mm, B: 3.0 mm, C: 10.9 mm
7353	ETLASP4-CHC	A: Ø 3.6 mm, B: 4.0 mm, C: 11.9 mm
7370	ETWASP1-CHC	A: Ø 4.0 mm, B: 1.0 mm, C: 11.0 mm
7371	ETWASP2-CHC	A: Ø 4.0 mm, B: 2.0 mm, C: 12.0 mm
7372	ETWASP3-CHC	A: Ø 4.0 mm, B: 3.0 mm, C: 13.0 mm
7373	ETWASP4-CHC	A: Ø 4.0 mm, B: 4.0 mm, C: 14.0 mm
7374	ETWASP5-CHC	A: Ø 4.0 mm, B: 5.0 mm, C: 15.0 mm
7356	ETLAS3.2-CHC	A: Ø 3.2 mm, C: 9.0 mm
7357	ETLAS3.6-CHC	A: Ø 3.6 mm, C: 9.0 mm
7383	ETLAS4.0-CHC	A: Ø 4.0 mm, C: 11.0 mm
7358	TLAS4.0-CHC	A: Ø 4.0 mm, C: 9.2 mm

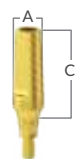

Legacy Prosthetic Line for Conical Narrow (CHC) Connection

20  
NCM

## CLASSIC CHC ESTHETIC ANGLED ABUTMENTS

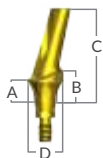

REF. NO.	Code	Dimensions
7360	ETLA15-CHC	A: 1.1 mm, B: 1.5 mm, C: 8.2 mm, D: Ø 3.9 mm
7361	ETLAL15-CHC	A: 1.1 mm, B: 1.5 mm C: 10.2 mm, D: Ø 3.9 mm
7362	ETLA25-CHC	A: 1.1 mm, B: 1.4 mm C: 8.2 mm, D: Ø 4.3 mm
7363	EA15-1.5CHC	A: 1.5 mm, B: 2.5 mm C: 9.5 mm, D: Ø 4.0 mm
7364	EA15-2.5CHC	A: 2.5 mm, B: 3.5 mm C: 10.5 mm, D: Ø 4.0 mm
7365	EA15-3.5CHC	A: 3.5 mm, B: 4.5 mm C: 11.5 mm, D: Ø 4.0 mm
7366	EA25-1.5CHC	A: 1.5 mm, B: 2.5 mm C: 9.5 mm, D: Ø 4.0 mm
7367	EA25-2.5CHC	A: 2.5 mm, B: 3.5 mm C: 10.5 mm, D: Ø 4.0 mm"
7368	EA25-3.5CHC	A: 3.5 mm, B: 4.5 mm C: 11.5 mm, D: Ø 4.0 mm

## CLASSIC CHC TITANIUM ABUTMENT SCREW



REF. NO.	Code
7345	STLA-CHC

### TECHNICAL INFORMATION:

**Material:** Titanium

**Recommended Tightening Torque:**

- Manually tighten healing abutments, transfers & analogs
- 20 NCM for straight & angled abutments

**Required Drivers:**

- 1.25mm prosthetic hex drivers (see page 114)

# INTERNAL HEX PROSTHETIC SYSTEM



High stability  
to lateral forces



High stability of the  
implant screw



Long term  
esthetic results



Simple restoration  
process



Internal Hex Connection  
**PROSTHETIC LINE**

**IH**



# HEALING ABUTMENTS

MANUAL  
TIGHTENING  
10 NCM

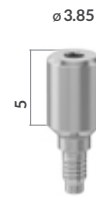
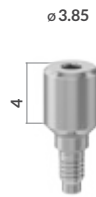
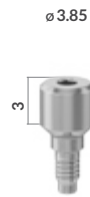

∅ 3.85

Code	HSS3	HSS4	HSS5
Ref. No.	112	114	113

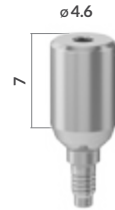
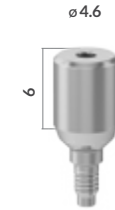
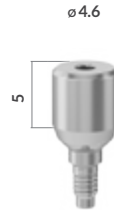
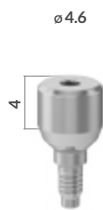
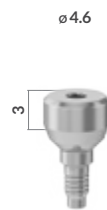

∅ 4.6

Code	HS2	HS3	HS4	HS5	HS6	HS7
Ref. No.	116	109	117	110	118	119

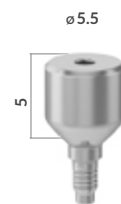
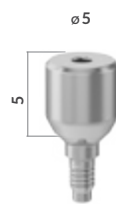

∅ 5 - ∅ 5.5

Code	HS5-3	HS5-5	HS5.5-3	HS5.5-5
Ref. No.	124	125	126	127

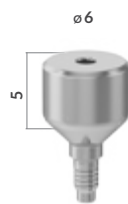

∅ 6 - ∅ 7

Code	HS6-3	HS6-5	HS7-3
Ref. No.	128	129	130

## TECHNICAL INFORMATION:

**Material:** Titanium

**Recommended Tightening Torque:** Manual tightening

**Required Drivers:** 1.25mm prosthetic hex drivers (see page 114)

- Laser marking to ensure easy identification of height and diameter





## TEMPORARY TITANIUM ABUTMENTS

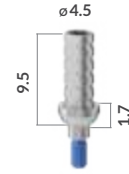
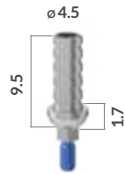

15 NCM

Code	TLAC-AR	TLAC-R
Ref. No.	5200	5220

### TECHNICAL INFORMATION:

Material: Titanium

Tightening Torque: 15NCM

Required drivers: 1.25mm prosthetic hex drivers (see page 114)

## STRAIGHT PEEK ABUTMENTS



15 NCM

Code	TPA1	TPA2	TPA3
Ref. No.	5416	5417	5418

## ANGLED PEEK ABUTMENTS



Code	TPA15-1	TPA15-2	TPA15-3	TPA25-1	TPA25-2
Ref. No.	5419	5420	5421	5422	5423

### TECHNICAL INFORMATION:

Material: PEEK Polymer | Vital for 180 days

Tightening Torque: 15 NCM

Required Drivers: 1.25mm prosthetic hex drivers (see page 114)

# IMPLANT IMPRESSION

MANUAL  
TIGHTENING  
10 NCM

## CLOSED TRAY TRANSFERS

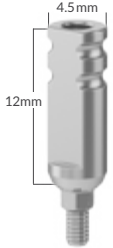
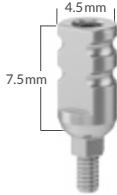
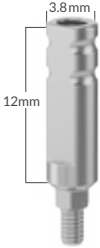
	STANDARD	SHORT	SLIM
			
Code	HLT	HLTS	HLTLS
Ref. No.	5060	5170	5062

## OPEN TRAY TRANSFERS

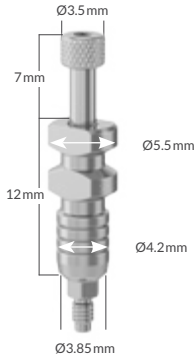
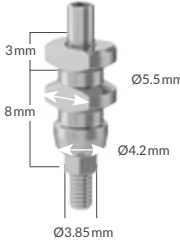
	STANDARD	SHORT
		
Code	HLTO	HLTOS
Ref. No.	5061	5171

### TECHNICAL INFORMATION:

**Material:** Titanium

**Recommended Tightening Torque:** Manual tightening

**Required Drivers:** 1.25mm prosthetic hex drivers (see page 114)

☉ Screw is included

## CLOSED TRAY IMPRESSION

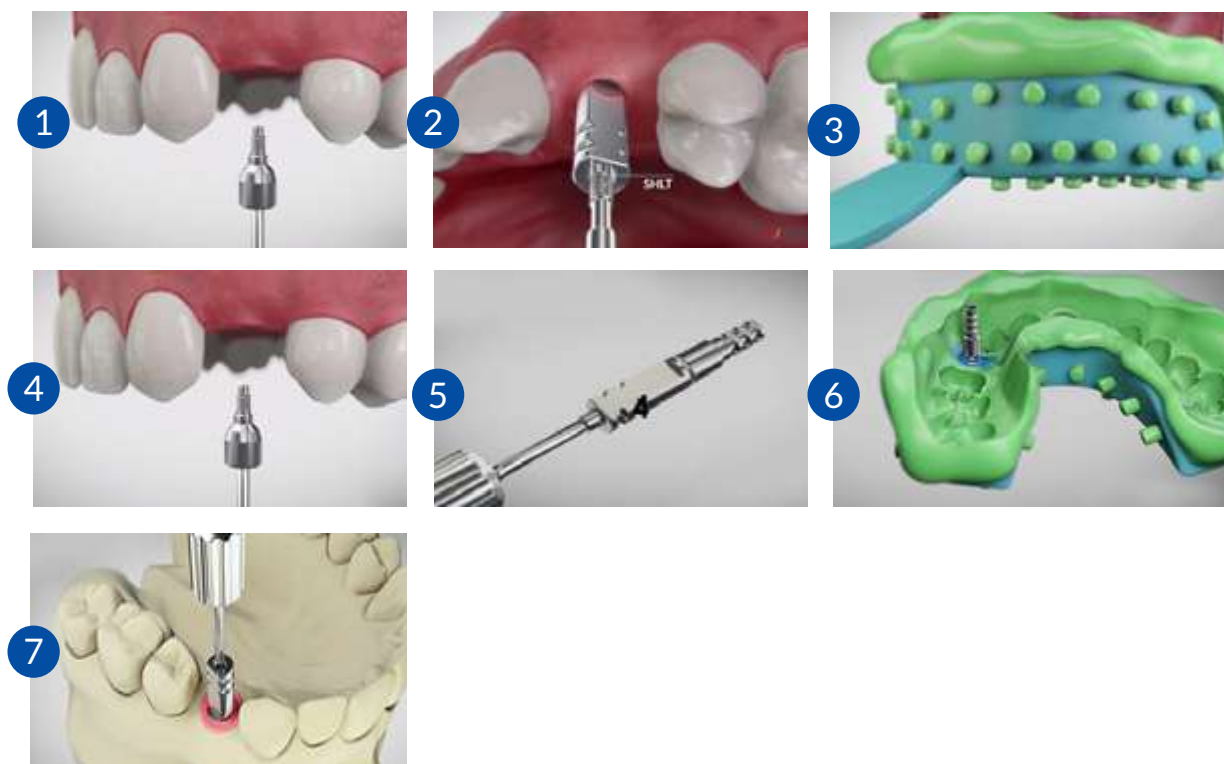

## OPEN TRAY IMPRESSION

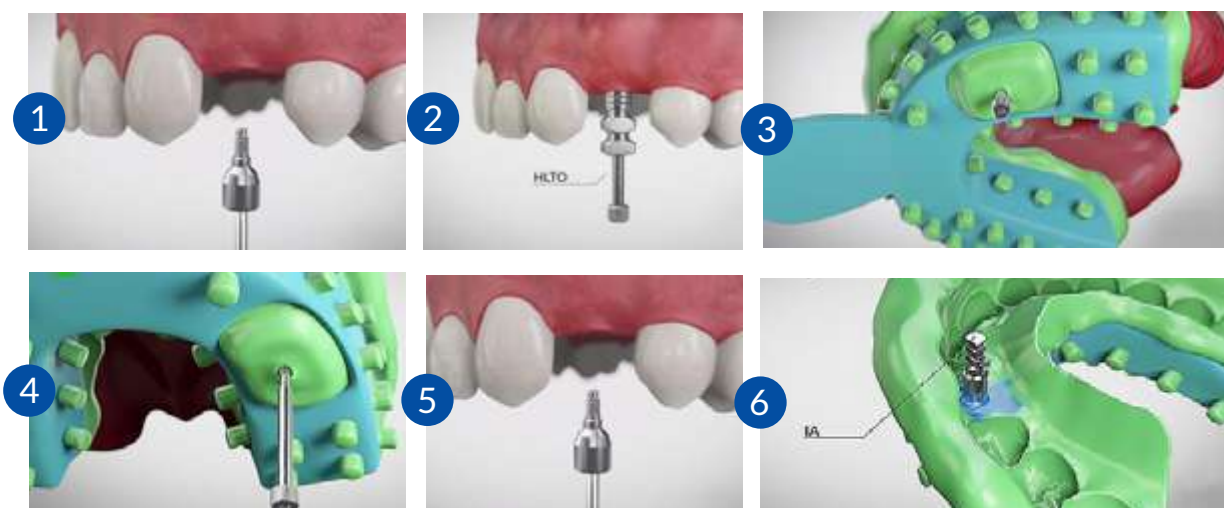

## IMPRESSION

Before taking the impression, attach the transfer to the implant with the flat surface facing the buccal area.

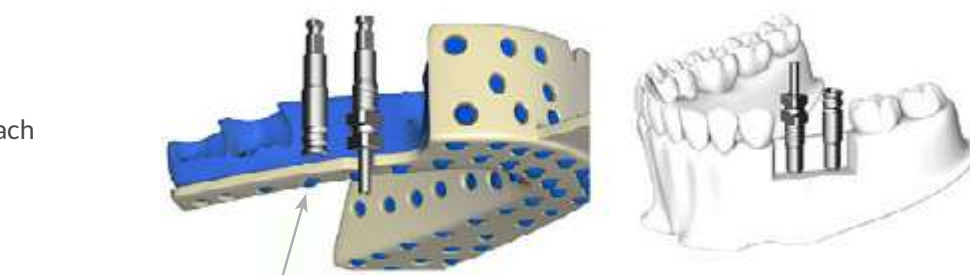

# CEMENT-RETAINED RESTORATIONS

30  
NCM

## CLASSIC & ESTHETIC STRAIGHT ABUTMENTS

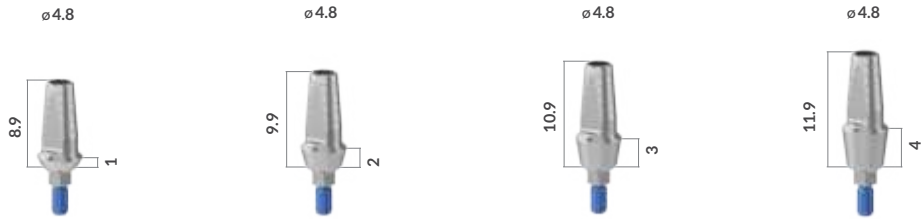

Code	TLASP1	TLASP2	TLASP3	TLASP4
Ref. No.	5366	5367	5368	5369

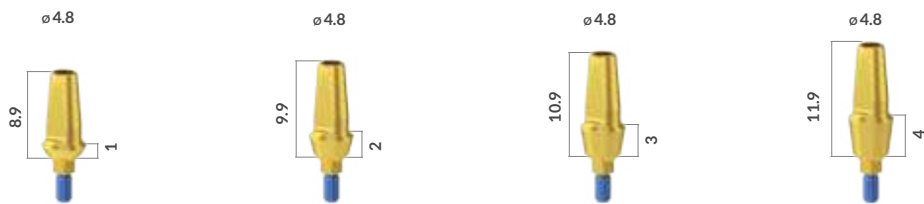

Code	ETLASP1	ETLASP2	ETLASP3	ETLASP4
Ref. No.	5352	5353	5354	5355



Code	HTLASP
Ref. No.	5364*

\* The HTLASP plastic transfer is suitable for TLASP and ETLASP abutments

## ABUTMENT LEVEL IMPRESSION TAKING WITH TLASP/ETLASP ABUTMENTS & HTLASP PLASTIC TRANSFER



- Measure the soft tissue height, and choose the suitable TLASP/ETLASP abutment
- Manually screw the abutment onto the implant, preferably with the flat surface facing buccally
- Position the HTLASP Plastic Transfer onto the abutment
- Press down on the plastic transfer, until you feel a "click" indicating it is properly positioned
- Take the impression
- Send the impression with the analog to the dental laboratory



30 NCM

## CLASSIC STRAIGHT ABUTMENTS

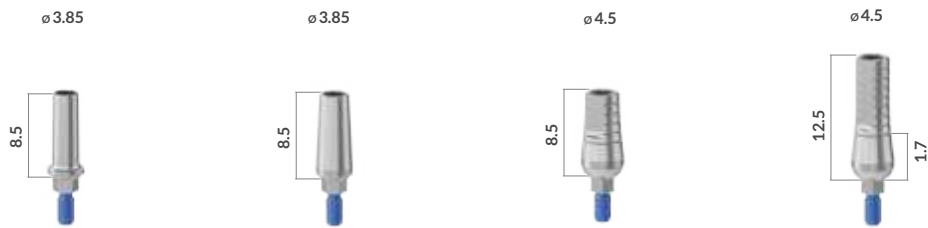

Code	TLASSP	TLAS	TLA	TLAL
Ref. No.	5403	5150	5030	5140

## ESTHETIC CLASSIC ABUTMENTS



Code	ETLAS	ETLA
Ref. No.	5155	5031

## CLASSIC WIDE ABUTMENTS

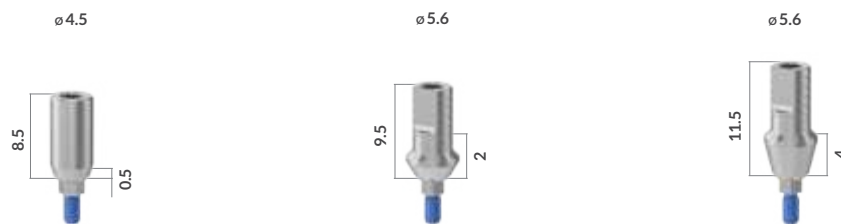

Code	TLAW	TLAO2	TLAO4
Ref. No.	5340	5182	5362

### TECHNICAL INFORMATION:

Material: Titanium

Recommended Tightening Torque: 30NCM

Required Drivers: 1.25mm prosthetic hex drivers (see page 114)



# CEMENT-RETAINED RESTORATIONS

30  
NCM

## CLASSIC ANGLED TITANIUM ABUTMENTS

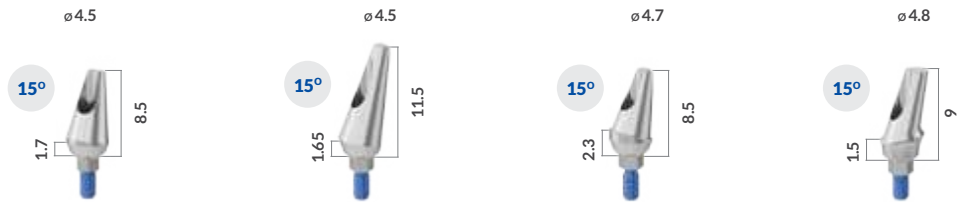

Code	TLA 15	TLAL 15	TLA 15B	TLA 15BB
Ref. No.	5090	5092	5091	5098

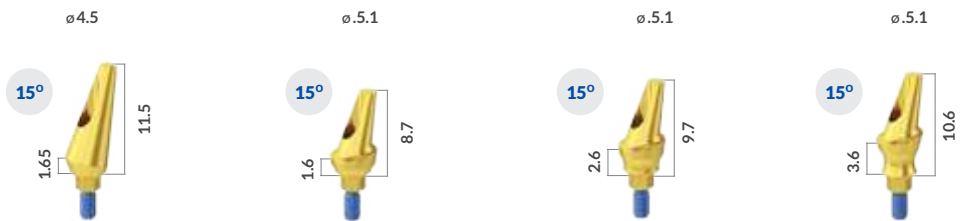

Code	ETLAL 15	EAAS 15	EAA 15	EAAH 15
Ref. No.	5094	5410	5411	5412



Code	TLA 25	TLAL 25	TLA 35
Ref. No.	5130	5134	5136

\* Compatible screw Ref.# 5127

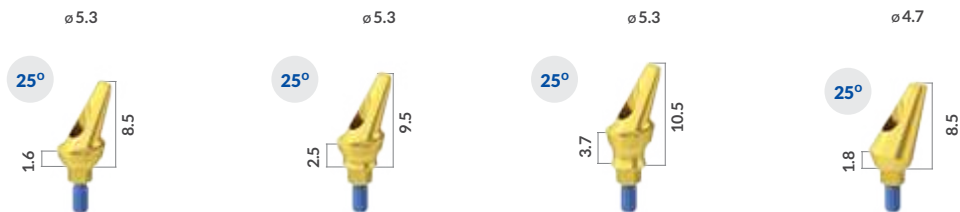

Code	EAAS 25	EAA 25	EAAH 25	ETLA25
Ref. No.	5413	5414	5415	5131

### TECHNICAL INFORMATION:

Material: Titanium

Recommended Tightening Torque: 30NCM

Required Drivers: 1.25mm prosthetic hex drivers (see page 114)

## PLASTIC ABUTMENT FOR CASTING

30 NCM



Code	PLA	PLA-R
Ref. No.	5040	5041

## IMPLANT ANALOGS

Implant analog, IA Ref. No. 5080, is suitable for use with all implant diameters.  
 Implant analog, IA5 Ref. No. 5280, is suitable for use with SPIRAL & DFI implants  $\varnothing 5$ .

STANDARD	WIDE	MULTI-UNIT	DIGITAL IMPRESSION
			<p>For resin printed models</p>
Code	IA	IA5	AN-PM-IH
Ref. No.	5080	5280	5457

MANUAL TIGHTENING  
10 NCM

## TITANIUM SCREWS



Code	STLAS	STLAT*	STLASH**	STLA_IH_60_DEG	RS
Ref. No.	5122	5121	5127	5462	5110
Instructions	* Specially coated, for laboratory use only. ** To be used only with the TLA36 abutment. Ref. 5136 (Page 94)			For Ti-Bases	Retrieval screw for CS & IH connections

### TECHNICAL INFORMATION:

**Material:** Plastic abutments- PET | Titanium

**Recommended Tightening Torque:** Plastic abutments 30 NCM | Implant analogs- manual tightening

**Required Drivers:** 1.25mm prosthetic hex drivers (see page 114)

# SCREW-RETAINED RESTORATIONS

30  
NCM

## Multi-Unit Abutment System

### STRAIGHT MULTI-UNIT ABUTMENTS

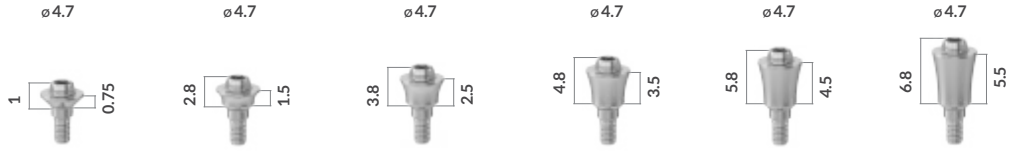

Code	TCT0.5-N	TCT1.5-N	TCT2.5-N	TCT3.5-N	TCT4.5-N	TCT5.5-N
Ref. No.	5221	5222	5223	5252	5253	5254

### ANGLED MULTI-UNIT ABUTMENTS

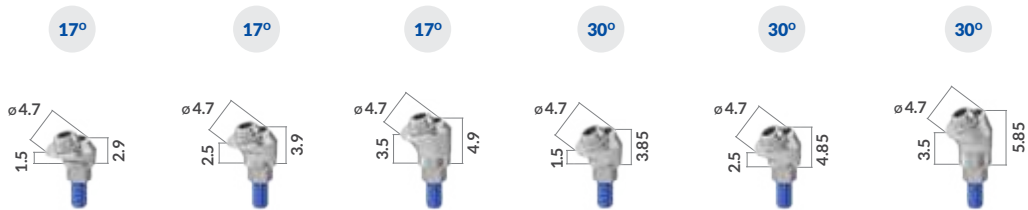

Code	AU 17-1.5 IH	AU 17-2.5 IH	AU 17-3.5 IH	AU 30-1.5 IH	AU 30-2.5 IH	AU 30-3.5 IH
Ref. No.	5432	5433	5434	5437	5438	5439

### HBC ABUTMENTS - FOR SINGLE TOOTH RESTORATION

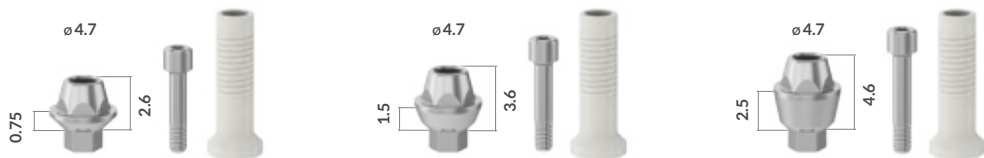

Code	HBC 0.5	HBC 1.5	HBC 2.5
Ref. No.	6040	6041	6042





# SCREW-RETAINED RESTORATIONS

## On Top Components

### BURNOUT SLEEVES



Code	PST-N-AR	PST-N
Ref. No.	*5217 $\triangle$	*5218 $\circ$

### ANALOG

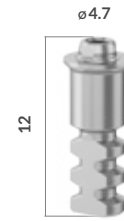

Code	BTT-N
Ref. No.	5211

\*Screw No. 6093 is included

### OPEN TRAY TRANSFERS

MANUAL TIGHTENING  
10 NCM

### CLOSED TRAY TRANSFER

### TEMPORARY ABUTMENT

20 NCM

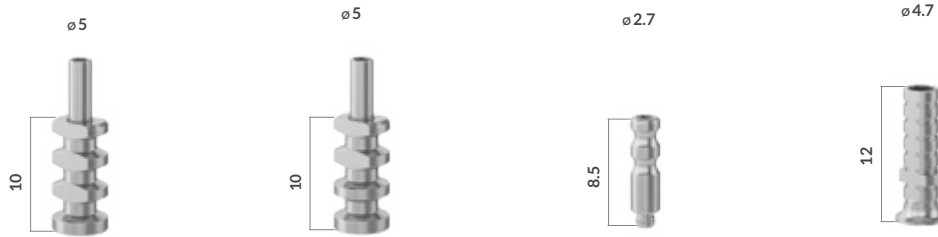

Code	TST-N	TST-N-R	TS-N	TTA-N
Ref. No.	5231 $\triangle$	5248 $\circ$	5235	** 5216

\*\*Screw No. 6092 is included

MANUAL TIGHTENING  
10 NCM

### PRO HEALING ABUTMENTS



### SCREWS



20 NCM

Code	HCT4-N	HCT6-N	SF-N	SFT-N
Ref. No.	5236	5237	6092	6093**

\*\* Black coated screw for lab use

### TECHNICAL INFORMATION:

**Material:** Titanium

**Required Drivers:** (see page 114):

- 1.25mm prosthetic hex drivers for angled multi-units abutments
- 1.5mm prosthetic hex drivers for straight multi-units abutments





**Recommended Tightening Torque:**



- Manually tighten impression transfers & healing abutments
- 30 NCM for straight & angled Multi-Unit Abutments
- 20 NCM for temporary fixture & screws



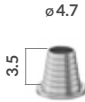

# CAD/CAM RESTORATIONS

## MULTI-UNIT CAD/CAM COMPONENTS

DUAL USE SCAN BODIES FOR MULTI-UNITS			ANALOG & INSERSION TOOL	
	ENGAGED	NON-ENGAGED		
				
Code	IOSB-TCT-N	IOSB-TCT-N-R	AN -PM -TCT -N	APMT_IH_CS
Ref. No.	5003 $\triangle$	3883 $\circ$	5456	5459
Instructions	For single crown restorations with multi-unit angled abutments	For bridge/bar restorations with multi-unit straight and angled abutments	Multi-Unit/TCT analog for 3D printed model	Insertion tool for analog 3D printed model IH, CS, TCT

ADHESIVE COPINGS FOR MULTI-UNITS			
	ENGAGED (For single tooth restorations)	NON-ENGAGED (For bar/bridge restorations)	
			
Code	TAC-TCT-N	TAC-TCT-N-R	AC-R-4.5
Ref. No.	5028 $\triangle$	5029 $\circ$	5039 $\circ$
Instructions			Gold anodized

TITANIUM SCREWS FOR MULTI-UNIT SYSTEM			
			
Code	SF-N	SFT-N	S-DM-SR
Ref. No.	6092	6093	4994
Instructions	Fixation screw for Multi-Unit restoration	Black coated screw for Lab	Direct mounting on metal frame. Should not be used for full zirconia or ceramic restorations

### TECHNICAL INFORMATION:

**Material:** Dual use scan body - PEEK and titanium | Adhesive copings, analogs & screws- titanium

**Recommended Tightening Torque:** Dual use scan body- manual tightening | Restoration cemented to adhesive coping, fixation screw, direct mounting screw- 20 NCM

DUAL USE SCAN BODY		ANALOG	PRE-MILLED BLANKS	
Code	SB-IH	AN_PM_IH	BA-PF-IH	WBA-PF-IH
Ref. No.	5019	5457	4988	4989
Instructions	<ul style="list-style-type: none"> <li>* For lab and/or intra-oral use</li> <li>* Biocompatible &amp; reusable</li> <li>* Material: PEEK &amp; titanium</li> </ul>	For 3D printed model	For Preface® abutment holder. Screw included	

## TI-BASES

30 NCM

ENGAGED (For single tooth restorations)			NON-ENGAGED (For bar/bridge restorations)			
Code	CCTB-0.75-AR-IH	CCTB-1.5-AR-IH	CCTB-2.5-AR-IH	CCTB-0.75-R-IH	CCTB-1.5-R-IH	CCTB-2.5-R-IH
Ref. No.	4961	4962	4963	4964	4965	4966

\* Use with replacement screw 5462

WIDE TI-BASES	
<p>ENGAGED (For single tooth restorations)</p>	<p>NON-ENGAGED (For bar/bridge restorations)</p>
Code	WCCTB
Ref. No.	5007
Code	WCCTB-R
Ref. No.	5008

### TECHNICAL INFORMATION:

**Material:** dual use scan body - PEEK and titanium | Ti-Bases - titanium

**Recommended Tightening Torque:**

Dual use scan body - manual tightening | Ti-bases and Pre-milled blanks - 30 NCM

**Required Drivers:**

1.25mm prosthetic hex drivers (see page 114) | For analog Ref. No. 5457, use insertion tool Ref. No. 5459

# CAD/CAM RESTORATIONS

**TI-BASES** suitable for use with Cerec System (Sirona's L Blocks), 3shape and exocad software

					SCAN POST
Code	CCTB-IH-SI	SiTB_IH_1.5	SiTB_IH_2.5	SiTB_IH_3.5	CCSP-IH-SI
Ref. No.	4980	5464	5465	5466	4984
Instructions	For scan and/or restoration use				For scanning purpose only
	Use replacement screw 5122	Use replacement screw 5462			

## TECHNICAL INFORMATION:

**Material:** Dual use scan body - PEEK and titanium | Ti-Bases - titanium

**Recommended Tightening Torque:** Dual use scan body - manual tightening | Ti-bases and Pre-milled blanks - 30 NCM

**Required Drivers:** 1.25mm prosthetic hex drivers (see page 114) | For analog Ref. No. 3838, use insertion tool Ref. No. 5459



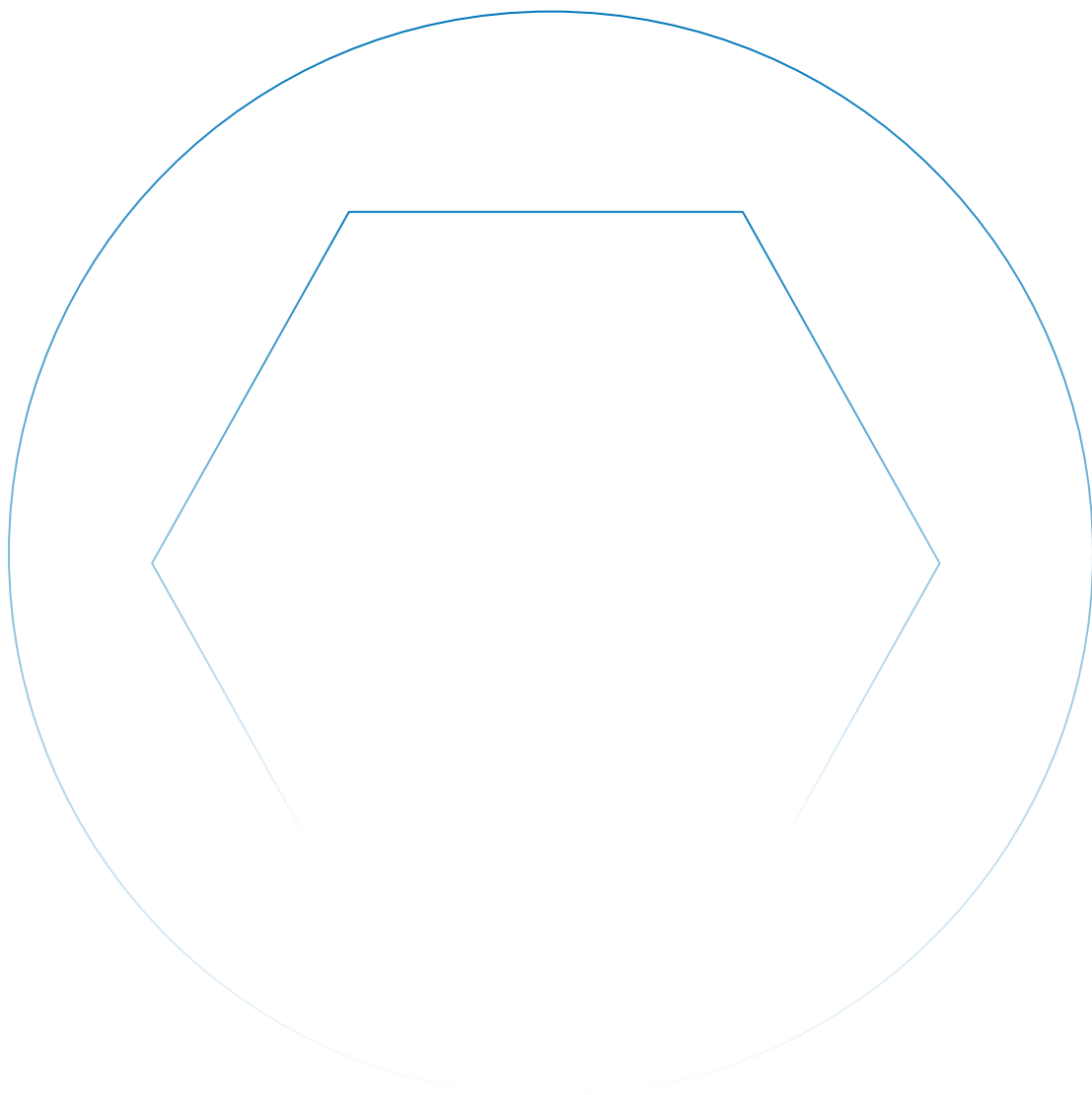

# OVERDENTURE RESTORATIONS

## ALPHALOC ABUTMENT SYSTEM

30  
NCM

### ALPHALOC KIT

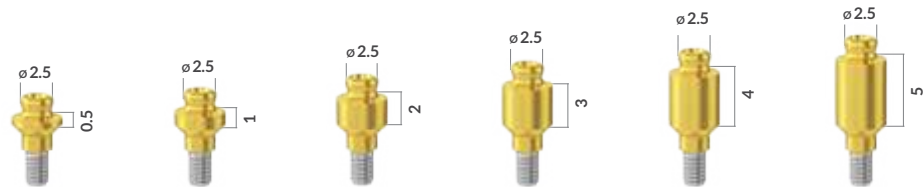

Code	AK0.5	AK1	AK2	AK3	AK4	AK5
Ref. No.	4867	4868	4869	4870	4871	4872

Each AlphaLoc kit includes :

AlphaLoc abutment (of the selected gingival height), 1 stainless steel metal housing, 4 retentive caps, 1 block-out spacer, 1 laboratory cap

### ALPHALOC PROCESSING PACKAGE



### ALPHALOC RETENTIVE CAPS



Code	AMPP	AMSTR	AMSTA	AMSOF	AMESO
Ref. No.	4875	4876	4877	4878	4879
Includes	Stainless steel metal housing, block-out spacer, nylon retentive caps (violet, clear, pink and yellow), laboratory cap (black)	Violet (strong retention)	Clear (standard retention)	Pink (soft retention)	Yellow (extra soft retention)
		Each package contains 4 units of the same colored retentive caps			

## ALPHALOC ACCESSORIES

LABORATORY CAP  
(BLACK)

BLOCK OUT  
SPACER

IMPRESSION  
COPING

MALE  
ANALOG

INSERTION  
TOOL \*

EXTRACTION  
TOOL \*



Content	4 Units	1 Unit	4 Units	4 Units	1 Unit	1 Unit
Code	AML	ABOS	AIC	AFA	AIT	AET
Ref. No.	4882	4883	4884	4885	4886*	4887*

\* In some markets, a dual-tip single instrument (for cap insertion and extraction) is available for order

## TITANIUM BALL ATTACHMENTS

30  
NCM

### STRAIGHT BALL ATTACHMENTS

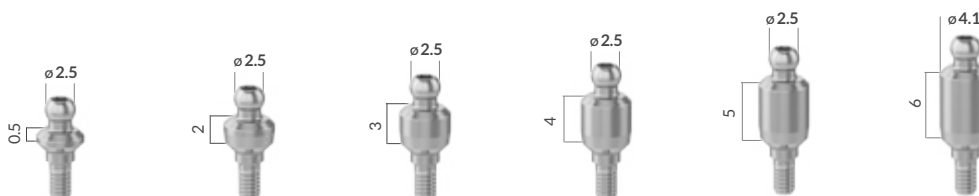

Code	TB 0.5	TB 2	TB 3	TB 4	TB 5	TB 6
Ref. No.	6260	6210	6280	6220	6270	6290
Instructions	For impression, use analog 5080 and IH transfers.					

### ANGLED BALL ATTACHMENTS



Code	TBAA2	TBAA3
Ref. No.	6304	6306
Instructions	Ball orientation towards the flat hex	

### NYLON CAP

Stainless steel  
Housing



Nylon Cap



Nylon Cap with  
Titanium Ring



Soft Nylon Cap



Code	H	NC	NCT	NCA
Ref. No.	6240	6250	6251	6253

### TECHNICAL INFORMATION:

**Material:** Titanium

**Recommended Tightening Torque:** 30 NCM

**Required Drivers:** 1.25mm prosthetic hex drivers (see page 114)







# SURGICAL INSTRUMENTS

## SIMPLANTOLOGY IN THE PALM OF YOUR HAND

We offer an extensive portfolio of surgical tools, kits & accessories, especially designed to make every dental procedure you perform, as simple, accurate, safe & comfortable as possible, for both you & for your patient. All our surgical kits, drills and tools are suitable for all Alpha-Bio Tec. implant systems and prosthetic parts.

# ONE SURGICAL KIT FOR ALL IMPLANT SYSTEMS

Designed for efficient workflows

Our universal kit is customizable, in size & content, to include all the tools you need to perform most of the clinical procedures at your clinic. In addition, all drills and tools are suitable for use with Alpha-Bio Tec. implant systems and prosthetic parts.



## SURGICAL KIT AT A GLANCE

- One kit for all implant systems
- Ergonomic and easy to use
- Light, compact & easy to carry
- Clear color-coded visual design for tools identification and easy and intuitive accessibility
- Dimension Bar for effectively measuring and verifying drill depth
- Autoclaveable

### Materials

- Box and tray- Radel®
- Bath- Stainless steel

## Surgical kit box dimensions

- Standard full-size kit: 19 cm X 14 cm X 6 cm (as shown above)
- Mini Kit: 10 cm X 8.5 cm X 5 cm



ⓘ The surgical kits displayed in this catalog are for illustration purposes only. The surgical kit box is provided empty. Contact your local representatives for more information regarding the content. Contents may vary in different markets.

## GUIDED SURGERY TOOL KIT (GSTK)

Guiding you to clinical success with ease & confidence

Everything you need for performing accurate and predictable guided surgery procedures using one comprehensive, autoclavable, color-coded kit.



-  The GSTK modular tray layout supports guided surgery procedures, from site preparation to final implantation

-  Compatible with all Alpha-Bio Tec. implants, for full or partial edentulous cases



-  Compatible with GSTK master sleeves (for fabrication and securing the surgical guide)



-  Supported by a selection of guided surgery software, enabling you to plan your cases with the software of your choice



-  For comprehensive information and specifications for the Guided Surgery Tool Kit's components, see pages 120-124

-  Available in selected countries only, subject to regulatory approval.



Our drills and stopper kit are designed for ease of use, durability & efficient workflows.

# DNT<sup>2</sup> COATED DRILLS

High Durability & High Performance with a Twist

## DESIGN FEATURES AND BENEFITS

- Low heat generation
- Color Coding for easy identification
- **Material:** Stainless steel with DNT<sup>2</sup> coating
- High contrast and clear depth marks
- Compatible with all drill stoppers

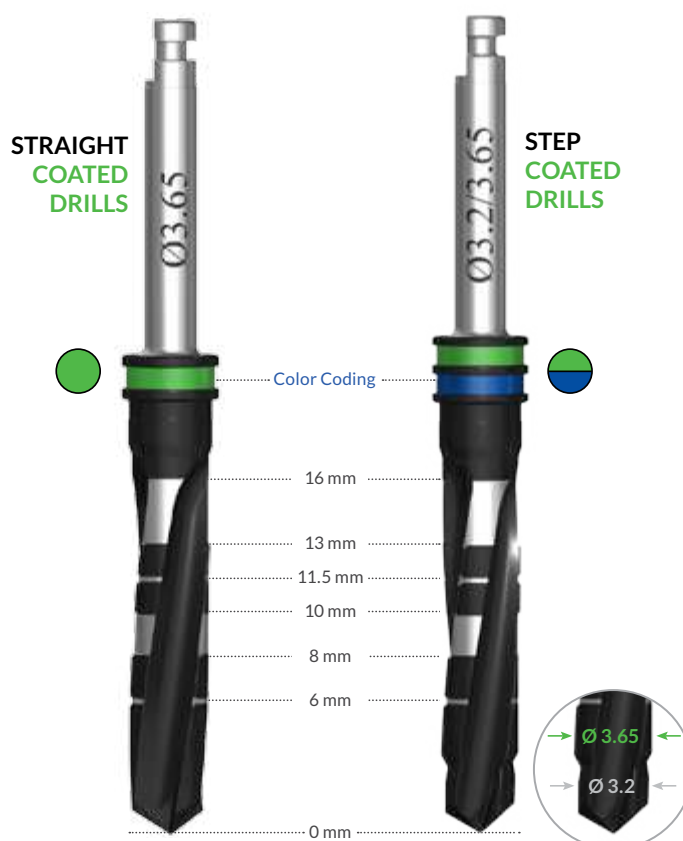

## STRAIGHT COATED DRILLS

	Ø 2.0	Ø 2.4	Ø 2.8	Ø 3.0	Ø 3.2	Ø 3.65	Ø 4.1	Ø 4.5	Ø 4.8	Ø 5.2	Ø 5.8
Code	BD2.0	BD2.4	BD2.8	BD3.0	BD3.2	BD3.65	BD4.1	BD4.5	BD4.8	BD5.2	BD5.8
Ref. No.	4550	4551	4552	4553	4554	4555	4556	4557	4558	4559	4560

## STEP COATED DRILLS

	Ø 2.0/2.4	Ø 2.4/2.8	Ø 2.8/3.0	Ø 2.8/3.2	Ø 3.2/3.65	Ø 3.65/4.1	Ø 4.1/4.5	Ø 4.5/4.8	Ø 4.8/5.2
Code	BSD2.0-2.4	BSD2.4-2.8	BSD2.8-3.0	BSD2.8-3.2	BSD3.2-3.65	BSD3.65-4.1	BSD4.1-4.5	BSD4.5-4.8	BSD4.8-5.2
Ref. No.	4590	4592	4593	4594	4595	4596	4597	4598	4599

# STOPPER KIT & STOPPERS

A Compact, Ergonomically Designed Stopper Kit

## STOPPER KIT (REF. NO. 4612)

### DESIGN FEATURES & BENEFITS

- Stoppers are clearly visible and easily attached to the drills from their dedicated slots
- Laser markings on both box and stoppers for easy identification
- Easy to extract stopper from drill with the removal grooves
- Autoclavable & easy to clean
- Provided with 20 stoppers

### Materials











- Box - Radel®, Cover - PPHT
- Dimensions: 13 cm X 9.5 cm X 3 cm













## DRILL STOPPERS

- Reusable & Autoclavable
- Compatible with Alpha-Bio Tec. Coated Drills

**Material:** Stainless steel

Drill Diameter	GROUP A: Ø 2.0 - Ø 2.4					GROUP B: Ø 2.8 - Ø 3.0				
Drill Depth	L6	L8	L10	L11.5	L13	L6	L8	L10	L11.5	L13
										
Code	DS-A-L6	DS-A-L8	DS-A-L10	DS-A-L11.5	DS-A-L13	DS-B-L6	DS-B-L8	DS-B-L10	DS-B-L11.5	DS-B-L13
Ref. No.	4561	4562	4563	4564	4565	4566	4567	4568	4569	4570

Drill Diameter	GROUP C: Ø 3.2 - Ø 3.65					GROUP D: Ø 4.1 - Ø 4.5				
Drill Depth	L6	L8	L10	L11.5	L13	L6	L8	L10	L11.5	L13
										
Code	DS-C-L6	DS-C-L8	DS-C-L10	DS-C-L11.5	DS-C-L13	DS-D-L6	DS-D-L8	DS-D-L10	DS-D-L11.5	DS-D-L13
Ref. No.	4573	4574	4575	4576	4577	4578	4579	4580	4581	4582

# SURGICAL DRILLS

	MARKING DRILL	ROUND BUR	DRILL EXTENSION
	<p>Diagram of a marking drill with diameter <math>\varnothing 1.5</math>. Length markings are shown at 0 mm, 6 mm, 8 mm, 10 mm, 11.5 mm, 13 mm, and 16 mm.</p>	<p>Diagram of a round bur with diameter <math>\varnothing 3</math>.</p>	<p>Diagram of a drill extension.</p>
Code	MRDX1.5	RB3	DX
Ref. No.	4712C	4304	4240
Instructions	For marking of the cortical plate of the alveolar crest	For various bone manipulations, such as penetration of the cortical plate of the alveolar crest	Extends all drills by 17.5 mm

	COUNTERSINK	TREPHINE BURS	
	<p>Diagram of a countersink with diameter range <math>\varnothing 2.7 - \varnothing 5.9</math>. Length markings are shown at 0 mm, 2.5 mm, 4.5 mm, 5.55 mm, and 7.8 mm. Diameter markings are shown at <math>\varnothing 2.7</math> mm, <math>\varnothing 3.85</math> mm, <math>\varnothing 4.2</math> mm, <math>\varnothing 5</math> mm, and <math>\varnothing 5.9</math> mm.</p>	<p>Diagram of a trephine bur with diameter <math>\varnothing 4</math>. Length markings are shown at 6 mm, 8 mm, 10 mm, 11.6 mm, 13 mm, 15 mm, and 16 mm. Diameter markings at the tip are <math>\varnothing 4</math> mm and <math>\varnothing 5</math> mm.</p>	<p>Diagram of a trephine bur with diameter <math>\varnothing 5</math>. Length markings are shown at 6 mm, 8 mm, 10 mm, 11.6 mm, 13 mm, 15 mm, and 16 mm. Diameter markings at the tip are <math>\varnothing 5</math> mm and <math>\varnothing 6</math> mm.</p>
Code	CS	DRT4	DRT5
Ref. No.	4672	4940	4950
Instructions	For preparation of a bevel within the cortical plate of the alveolar crest	For bone harvesting and implant removal	

**Material:** Stainless steel

# IMPLANT INSERTION TOOLS

Driven to Clinical Success

## IMPLANT INSERTION TOOLS FOR CONICAL CONNECTION IMPLANTS (CS &CHC)



SHORT

LONG

SHORT MOTOR MOUNT

LONG MOTOR MOUNT

MANUAL

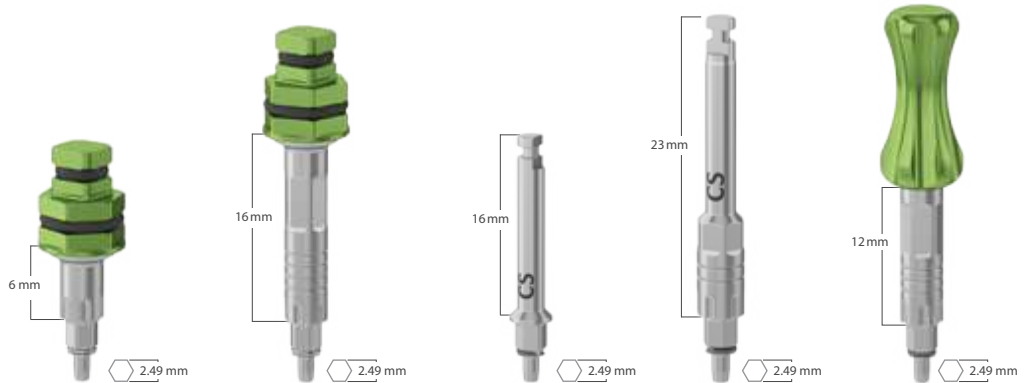

Code	ITD2.5 S CS	ITD2.5 L CS	IT2.5 SM CS	IT2.5 LM CS	MITD2.5-CS
Ref. No.	3801	3803	3804	3805	3806
Instructions	Fits hexagonal 6.35 mm or square 4 mm wrench ratchet		For use with a contra-angle motor		For manual use



SHORT

STANDARD

LONG

SHORT MOTOR MOUNT

LONG MOTOR MOUNT

MANUAL



Code	ITD2.1S-CHC	ITD2.1-CHC	ITD2.1L-CHC	IT2.1S M-CHC	IT2.1L M-CHC	MITD2.1 CHC
Ref. No.	7302	7305	7301	7304	7303	4147
Instructions	Fits hexagonal 6.35 mm or square 4 mm wrench ratchet		For use with a contra-angle motor		For manual use	



# IMPLANT INSERTION TOOLS

Driven to Clinical Success

## IMPLANT INSERTION TOOLS FOR INTERNAL HEX CONNECTION IMPLANTS (IH)

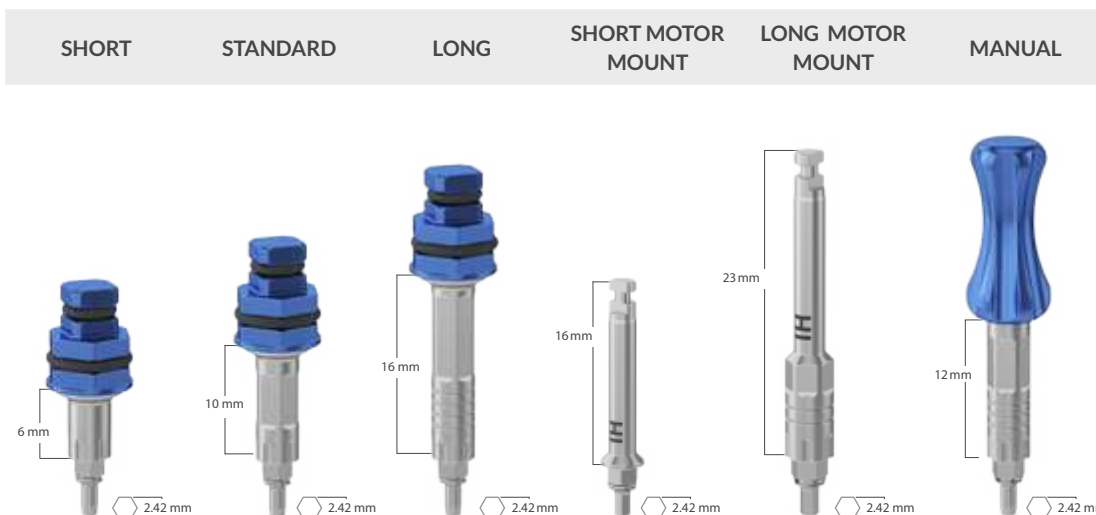







Code	G-ITDS2.5	G-ITDM2.5	G-ITDL2.5	GITS2.5/1.25	GITL2.5/1.25	MITD2.5-IH
Ref. No.	4142	4141	4140	4145	4143	4146
Instructions	Fits hexagonal 6.35 mm or square 4 mm wrench ratchet			For use with a contra-angle motor		For manual use

### IMPLANT INSERTION TOOLS:

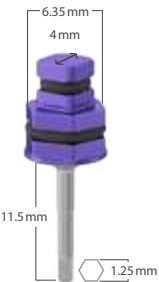
- Suitable for use with all Alpha-Bio Tec. implant connections (CS, CHC & IH).
- For use with a contra-angle motor, ratchet wrench or for manual tightening.
- Color coded for easy identification & intuitive use.

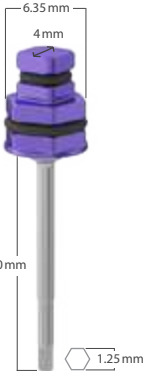
# PROSTHETIC INSERTION TOOLS

- Hex Drivers compatible with all Alpha-Bio Tec. prosthetic line.
- For use with a contra- angle motor, ratchet wrench or for manually tightening.

HEX DRIVERS 1.25 MM (STAINLESS STEEL)						
	SHORT	STANDARD	LONG	SHORT MANUAL GRIP DRIVER	MANUAL GRIP DRIVER	MOTOR MOUNT
						
Code	HTD 1.25 S	HTD 1.25	HTD 1.25L	HHSS 1.25	HHS 1.25	HT 1.25M
Ref. No.	4056	4055	4061	4053	4052	4165
Instructions	Fits hexagonal 6.35 mm or square 4 mm ratchet			For manual use		For use with a contra-angle motor
Compatible with all healing abutments, cover screws, transfer screws and most abutments.						

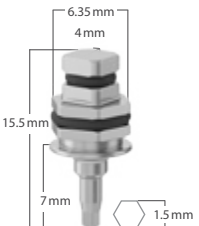
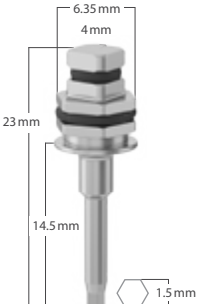
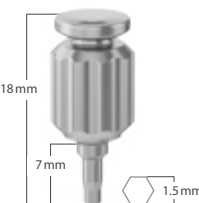
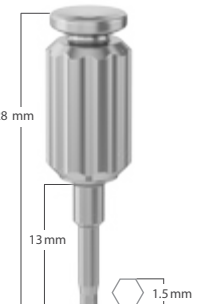
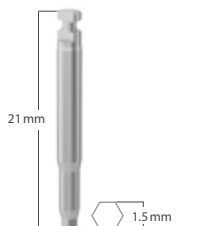
HEX DRIVERS 1.5 mm (STAINLESS STEEL)					
	SHORT	LONG	SHORT MANUAL DRIVER	LONG MANUAL DRIVER	MOTOR MOUNT
					
Code	HTD 1.5S	HTD 1.5	HHS 1.5	HHL 1.5	HT 1.5
Ref. No.	4058	4057	4059	4060	4168
Instructions	Fits hexagonal 6.35 mm or square 4 mm ratchet		For manual use		For use with a contra-angle motor
For use only with straight Multi-Unit abutments (See pages 62, 76 & 96)					

## TOOLS & ACCESSORIES

**SURGICAL SCREWDRIVER**  
(Stainless Steel)

Code: SDH  
Ref. No. 4220



Used with 6.35 mm hexagonal head.

**UNIVERSAL TORQUE RATCHET**  
10-45 Ncm (Stainless Steel)

Code: URT  
Ref. No. 4572



Allows clinicians to accurately apply the recommended torque when using prosthetic or surgical drivers.  
Can be adapted for use with the 4 mm square head drivers when using USH 4012.

### PARALLEL/DEPTH GUIDE (TITANIUM)

### PARALLEL GUIDE (TITANIUM)

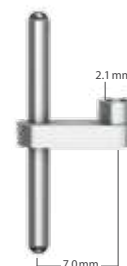
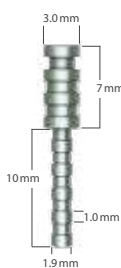
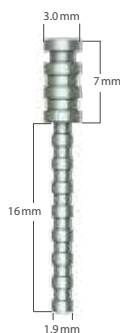

Code	PDG	PDGS	PG
Ref. No.	4080	4081	4082
Instructions	For accurate measurement of osteotomy depth, assessment of parallelism & X-Ray distortion. Each step is 1 mm.		Used for measuring spacing & parallelism during implant placement.

### IDG IMPLANT DEPTH PROBE (STAINLESS STEEL)



Code	IDG
Ref. No.	4100
Instructions	Double sided measuring probe: 1.9 mm width of the rounded apex is used for examinations of osteotomy made by the 2 mm drill. 2.7 mm width of the rounded apex is used for examinations of osteotomy made by the 2.8 mm drill. Can be used in various treatments: checking osteotomy depth, examination of the Schneiderian membrane, bone condensing and more.

# OMNIBASE TX DRIVERS

Experience Freedom: Flexibility & Esthetics from a New Angle

## TX DRIVERS FOR INSERTION/REMOVAL AT 0° - 25°



- Laser marking on top of the drivers for easy identification

MANUAL STANDARD TX DRIVER FOR ANGLED INSERTION	RATCHET STANDARD TX DRIVER FOR ANGLED INSERTION	MOTOR STANDARD TX DRIVER FOR ANGLED INSERTION
--	---	---

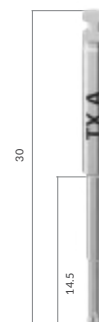
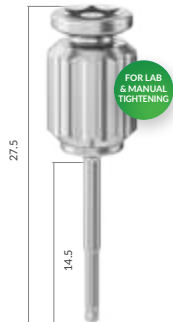

Code	AHD-S	ARD-SD	AMD
Ref. No.	5475	5548	5477

MANUAL LONG TX DRIVER FOR ANGLED INSERTION	RATCHET LONG TX DRIVER FOR ANGLED INSERTION	MOTOR LONG TX DRIVER FOR ANGLED INSERTION
--	---	---

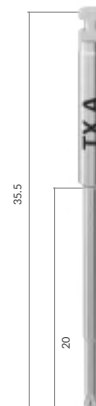
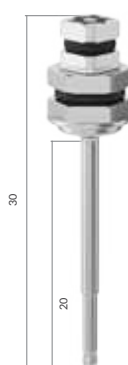
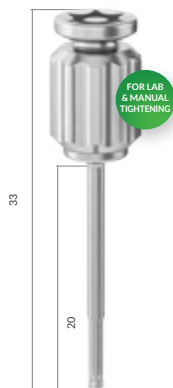

Code	AHD-L	ARD-L	AMD-L
Ref. No.	5546	5476	5547

# OMNIBASE TX DRIVERS

Experience Freedom: Flexibility & Esthetics from a New Angle

## TX DRIVERS FOR VERTICAL INSERTION/REMOVAL AT 0°



- Laser marking on top of the drivers for easy identification

MANUAL STANDARD TX DRIVER FOR VERTICAL INSERTION	RATCHET STANDARD TX DRIVER FOR VERTICAL INSERTION	MOTOR STANDARD TX DRIVER FOR VERTICAL INSERTION
--	---	---

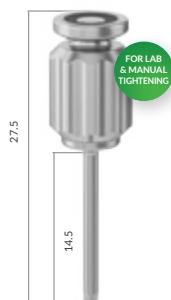

Code	VHD-S	VRD-SD	VMD
Ref. No.	5478	5496	5498

MANUAL STANDARD TX DRIVER FOR VERTICAL INSERTION	RATCHET LONG TX DRIVER FOR VERTICAL INSERTION	MOTOR LONG TX DRIVER FOR VERTICAL INSERTION
--	---	---

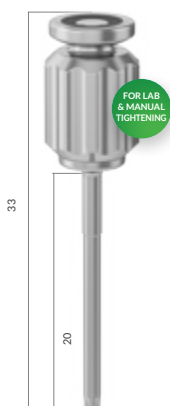

Code	VHD-L	VRD-L	VMD-L
Ref. No.	5479	5497	5495

### TECHNICAL INFORMATION:

**Material:** Stainless steel & titanium

**Recommended Tightening Torque :** Ratchet and motor drivers - CHC -20 NCM | CS - 30 NCM

**For the full Omnibase portfolio:**

- Conical Standard (CS) connection, see pages 66-67
- Conical Narrow Connection (CHC) connection, see pages 80-81

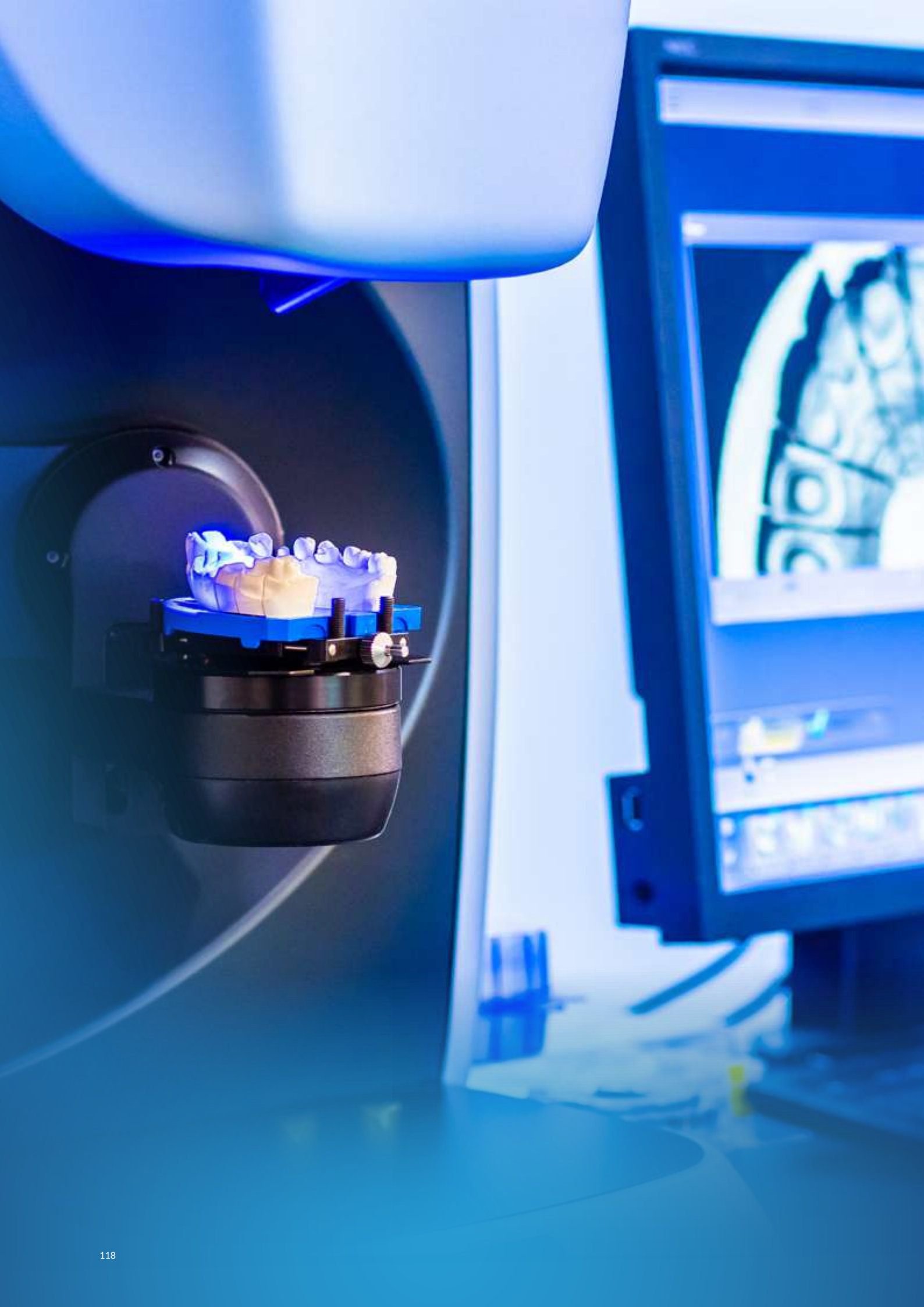



# DIGITAL SOLUTIONS

## ADVANCED DENTISTRY FOR PRECISION & CONFIDENCE

At Alpha- Bio Tec. we embrace technological advancement and dentistry digitalization to support the present and future needs for you & your patients. Our Guided Surgery Tool Kit (GSTK) is supported by a variety of digital planning software, making your work simpler, more precise, and minimally invasive, for your patients' confidence & comfort. Our digital CAD/CAM line offers a wide range of restoration products for Alpha-Bio Tec.'s Conical & Internal Hex connections.



# GUIDED SURGERY TOOL KIT GSTK

**GUIDING YOU TO CLINICAL SUCCESS WITH EASE & CONFIDENCE**

Everything you need for performing accurate and predictable guided surgery procedures using one comprehensive, autoclavable, color-coded kit.

*\*Available in selected countries only, subject to regulatory approval*



## GUIDED SURGERY TOOL KIT AT A GLANCE

-  Suitable for all Alpha-Bio Tec. implants, for fully or partial edentulous cases



-  Compatible with GSTK master sleeves (for fabrication and securing of the surgical guide)



-  Supported by a selection of guided surgery software enabling you to plan your cases with the software of your choice



-  Available in three layout configurations for enhanced efficiency & convenience:

Ref. No. KIT#65000	Full guided surgery kit for Internal Hex (IH) and Conical Narrow (CHC) implant connections
Ref. No. KIT#65002	Full guided surgery kit for Conical Standard (CS) & Conical Narrow (CHC) implant connections
Ref. No. KIT#65003	Full guided surgery kit for for all implant connections: Internal Hex (IH) and for Conical Standard (CS) and Conical Narrow (CHC) implant connections

**Note:**

\* The GUIDED SURGERY TOOL KIT image is for illustration purposes only.

\* The ratchet wrench is NOT included in the kit & is available for order separately.

\* Available in selected countries only, subject to regulatory approval.

# GUIDED SURGERY TOOL KIT AT A GLANCE

The GSTK modular tray layout supports guided surgery procedures, from site preparation to final implantation



1

**SITE PREPARATION**



Tissue punches, drills & pins for osteotomy preparation & surgical guide anchoring



2

**OSTEOTOMY**



Color coded drills for simplified, easy & intuitive drill sequence



3

**IMPLANT PLACEMENT**



Implant mounts & compatible screws



4

**TOOLS & ACCESSORIES**









A variety of tools for the surgical procedure





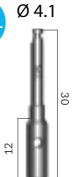

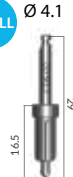
# GUIDED SURGERY TOOL KIT AT A GLANCE

## ORDERING INFORMATION



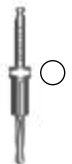
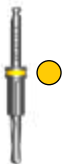
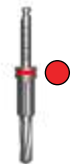





### 1 SITE PREPARATION

	TISSUE PUNCH		CRESTAL DRILL		LATERAL PIN	Ø 1.5 MILLING DRILL
	<b>SMALL</b> Ø 4.1	<b>LARGE</b> Ø 5.5	<b>SMALL</b> Ø 4.1	<b>LARGE</b> Ø 5.5		
						
CODE	TPS	TPL	CDS	CDL	LP	MCD1.5
REF. NO.	65003	65004	65005	65006	65047	65050













### 2 OSTEOTOMY (For each diameter and length: Qty 1)

	Ø 2.0 SURGICAL DRILLS		Ø 2.4 SURGICAL DRILLS		Ø 2.8 SURGICAL DRILLS		Ø 3.2 SURGICAL DRILLS		Ø 3.65 SURGICAL DRILLS		Ø 4.1 SURGICAL DRILLS		Ø 4.5 SURGICAL DRILLS	
														
LENGTH	CODE	REF. NO.	CODE	REF. NO.	CODE	REF. NO.	CODE	REF. NO.	CODE	REF. NO.	CODE	REF. NO.	CODE	REF. NO.
8 MM	CD2-8	65007	CD2.4-8	65070	CD2.8-8	65012	CD3.2-8	65017	CD3.65-8	65022	CD4.1-8	65027	CD4.5-8	65032
10 MM	CD2-10	65008	CD2.4-10	65071	CD2.8-10	65013	CD3.2-10	65018	CD3.65-10	65023	CD4.1-10	65028	CD4.5-10	65033
11.5 MM	CD2-11.5	65009	CD2.4-11.5	65072	CD2.8-11.5	65014	CD3.2-11.5	65019	CD3.65-11.5	65024	CD4.1-11.5	65029	CD4.5-11.5	65034
13 MM	CD2-13	65010	CD2.4-13	65073	CD2.8-13	65015	CD3.2-13	65020	CD3.65-13	65025	CD4.1-13	65030	CD4.5-13	65035
16 MM	CD2-16	65011	CD2.4-16	65074	CD2.8-16	65016	CD3.2-16	65021	CD3.65-16	65026	CD4.1-16	65031	CD4.5-16	65036

### 3 IMPLANT PLACEMENT

	IMPLANT MOUNT IH		IMPLANT MOUNT CS		IMPLANT MOUNT SCREW IH/CS	IMPLANT MOUNT CHC	IMPLANT MOUNT CHC SCREW
	<b>SMALL</b>	<b>LARGE</b>	<b>SMALL</b>	<b>LARGE</b>			
							
CODE	IMS	IML	IMSS	IMSL	IMHS	IMC	IMCS
REF. NO.	65037	65038	65064	65065	65039	65055	65056

### 4 TOOLS & ACCESSORIES

	SCREW-DRIVER	HEX DRIVER	IMPLANT MOUNT EXTENSION	HANDPIECE INSERTION ADAPTOR	IMPLANT MOUNT EXTRACTOR	UNIVERSAL SQUARE RATCHET HEAD ADAPTOR	L/S SLEEVE ADAPTOR DRIVER	SLEEVE ADAPTOR (Remove before implant insertion)	CRESTAL PIN	IMPLANT MOUNT IH DRIVERS	IMPLANT MOUNT CHC DRIVER		
	<b>SHORT</b>		<b>ONE SIZE</b> Ø 6			Enables use of 4 mm square driver head		Used for adapting the small diameter drills to the large sleeve (SLL)	<b>SMALL</b> <b>LARGE</b>	<b>SMALL</b> <b>LARGE</b>			
													
CODE	HHSS1.25	HTD1.25S	IMX	HIA	IME	USH	SAD	SLSA	CPS	CPL	IMSD	IMLD	IMCD
REF. NO.	4053	4056	65042	65044	65045	4012	65057	65058	65048	65049	65062	65063	65061

# SLEEVES



The sleeves are used in the fabrication of the surgical guide.

Master sleeves are available in two sizes:

- Small diameter SLS master sleeve for narrow diameter implants- up to Ø 3.75
- Wide diameter SLL master sleeve for standard diameter implants- Ø 4.2 and above

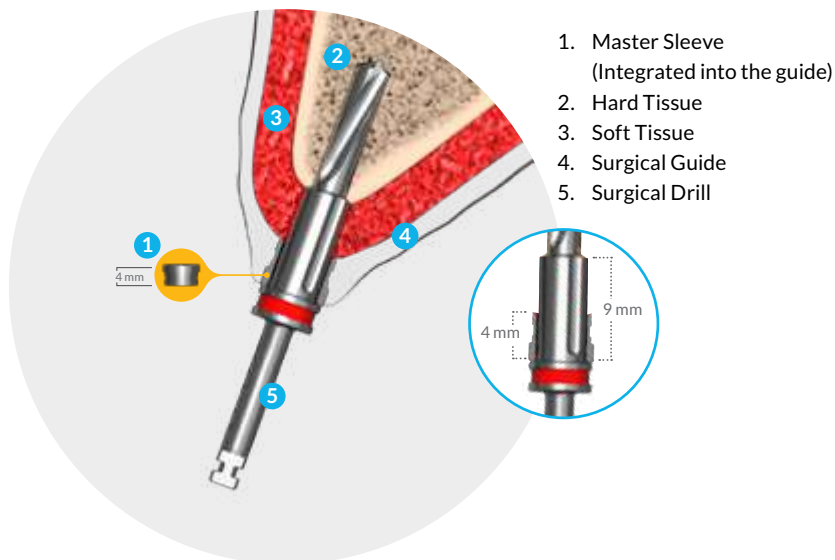
The securing sleeve is used for fixating the surgical guide in place, mainly for full edentulous cases



	MASTER SLEEVES For Guided Drilling & Implant Insertion		SECURING SLEEVE For Lateral Pin Support
	 Ø4.1 MM	 Ø5.5 MM	
CODE	SLS	SLL	SLSE
REF. NO.	66012	66013	66014
QTY.	5	5	5
INFO.	For Ø 3.2, Ø 3.3, Ø 3.5, Ø 3.7N, Ø 3.75 mm implants	For Ø 4.2, Ø 4.65, Ø 5.0, and Ø 5.3 mm implants	For 1.5 mm drill and lateral pin

## NOTES:

- When using the Ø5.5 mm sleeve, an adaptor should be used in the initial drilling sequence to correspond with the tool size. If sleeve adaptors are used for the site preparation and osteotomy stages, they must be removed before inserting the implant through the guide (when applicable).
- Drills and implant mounts are prolonged by a fixed 9 mm to meet the extra height attained by the surgical guide, i.e. the tool's stopper is located exactly 9 mm above the implant level.
- Master sleeves and securing sleeves are not supplied with the GSTK box.
- Sleeves are available for ordering separately (5 units per package).

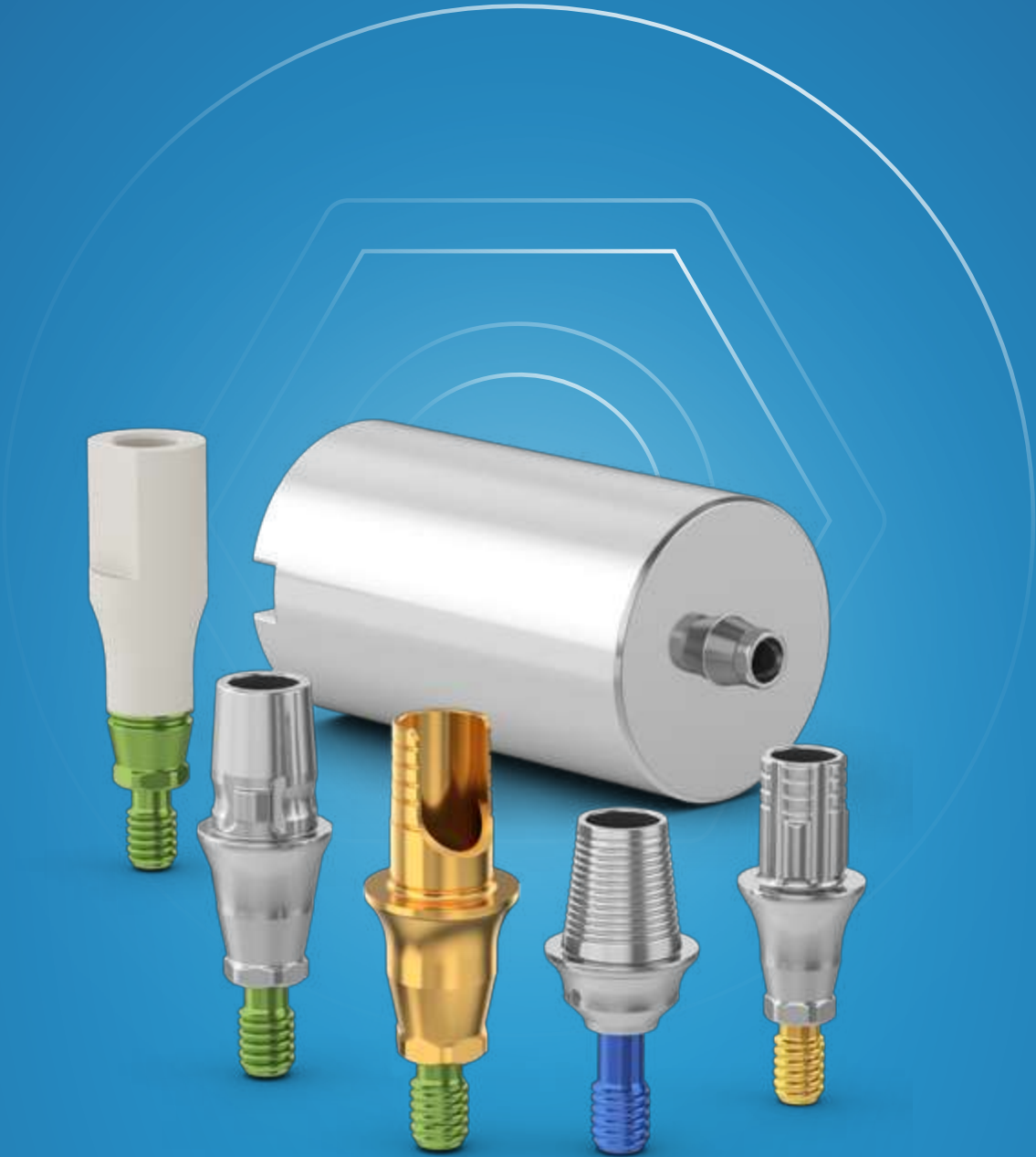

# CAD/CAM

**ENABLING PRECISE, DIMENSIONALLY STABLE,  
CUSTOMIZED RESTORATIONS**

For each of our implant connections we offer a wide range of CAD/CAM parts, for ease of use and high esthetic appearance.

# CAD/CAM RESTORATIONS

## Bringing 4 decades of excellence & precision into our CAD/CAM products and digital libraries

For each of our implant-abutment connections (conical & internal hex), we offer a wide range of CAD/CAM digital solutions, for ease of use and high esthetics. All CAD/CAM components feature original Alpha-Bio Tec. connections with the exact tolerances, ensuring best reliable implant to restoration fit, and offer solutions for single tooth and bridge restorations. The CAD/CAM portfolio comprises: scan bodies, Ti-bases (titanium bases) & Omnibases.

### Dual Use Scan Bodies

- Bio-compatible & autoclavable scan bodies for intra-oral & desktop scanning.
- Unique geometry for the precise and accurate transfer of implant position, trajectory and orientation to the CAD system.
- Body made of PEEK, a biocompatible material, which allows the optical digital detection in the scanned region.
- Base made of titanium, also a biocompatible material. The base provides support for the top part, even after repeated use.



### Titanium Bases (Ti-bases)

- Used as bases for digital restorations
- Available in a wide range of gingival heights



## CAD/CAM RESTORATIONS

### Pre-Milled Blanks

- Used as raw material for CAM fabrication of a single (monolithic) titanium abutment
- Original pre-milled implant connection is fabricated with the exact tolerances, ensuring best reliable implant to restoration fit.
- Fits Medentika's® Preface abutment holder



### Adhesive Copings

- Used as adapters for screw-retained zirconia restorations at abutment level
- For multi-unit angled and straight abutments (TCT-N connection)
- Indicated in cases in which a metal frame is not planned (since zirconia restorations may not withstand the screw forces)
- A direct mounting screw is available for restorations without adhesive copings



### CAD/CAM Software Libraries

- Contain all relevant CAD/CAM components: Scan Bodies, Ti-Bases, Adhesive Copings, Pre-Milled Blanks, Screws & Analogs.
- Enable simple and easy restoration design and manufacturing process
- Support all Alpha-Bio Tec. implant connections

3shape 

exocad

 dental wings

View the Full CAD/CAM prosthetic portfolio for all Alpha-Bio Tec. implant-abutment connections:

- Conical Standard (CS)- **pages 57-70**
- Conical Narrow (CHC)- **pages 71-85**
- Internal Hex (IH)- see **pages 86-103**

Visit our website to download Alpha-Bio Tec. digital libraries for CAD/CAM systems





omniBASE™

**EXPERIENCE FREEDOM**

FLEXIBILITY & ESTHETICS FROM A NEW ANGLE



## Experience Freedom: Flexibility & Esthetics from a New Angle

Screw-retained implant-supported restorations have proven advantages over cement-retained restorations, such as retrievability, no risk of residual cement & fewer biological complications. However, it is not always possible to place implants in the ideal angulation for screw retained restorations.

Alpha-Bio Tec. Omnibase abutments are designed to resolve this challenge.

The Omnibase is a Ti-Base used in CAD/CAM screw-retained restorations and enables the dental technician the flexibility to design a restoration with a screw access channel at a favorable position & angle (0°- 25°). This is particularly beneficial for improving esthetics, greater accessibility in the anterior region & in limited occlusal spaces.

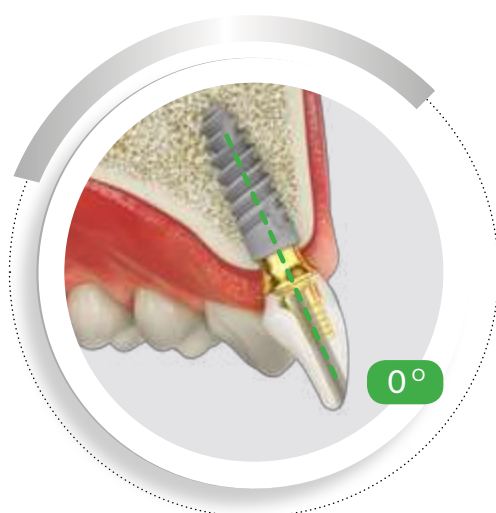

SCREW ACCESS CHANNEL AT 0°

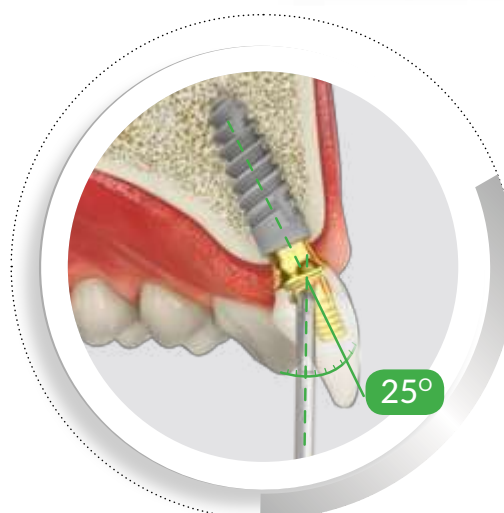

SCREW ACCESS CHANNEL AT A FAVORABLE POSITION 25°

The Omnibase Ti-Bases have a narrow concave emergence profile & are suitable for cases of subcrestal implant placement.

### DESIGN FEATURES & CLINICAL BENEFITS

- Standard & customizable Ti-bases
- A wide range of gingival heights
- Retrievable screw for ease of use & maintenance
- New concave emergence profile & gold anodization
- Suitable for subcrestal implant placement
- High esthetic results

■ Supporting digital libraries: exocad™, 3shape™

#### For the full Omnibase portfolio:

- Conical Standard (CS) connection, see pages 66-67
- Conical Narrow Connection (CHC) connection, see pages 80-81





# REGENERATIVE SOLUTIONS

## STABILITY AND GROWTH

Alpha-Bio Tec. offers a range of regenerative materials, suitable for a variety of clinical indications, to enable you to perform safe and successful Guided Bone Regeneration (GBR) and Guided Tissue Regeneration (GTR) procedures.

# xenobone Bovine Bone Graft Material

Bovine bone graft material for stability & Growth

With Alpha-Bio Tec. xenobone™, you provide your patients with predictable, osseo-regenerative, and highly reliable, long-term treatment outcomes. Made from 100% BSE-free, Australian origin cancellous bovine bone, Alpha-Bio Tec. xenobone's multi-porous structure and unique Octacalcium Phosphate (OCP) coating, enhances predictability, bone formation, and stability in any bone regeneration procedure.

## Features & Clinical Advantages



Enabling the attraction of blood to the graft, an essential step for new bone formation

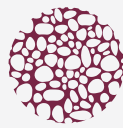

Allowing capillaries ingrowth, creating pathways for the osteoprogenitor cells to the regeneration site



Promoting osteoblast differentiation and induces new bone formation

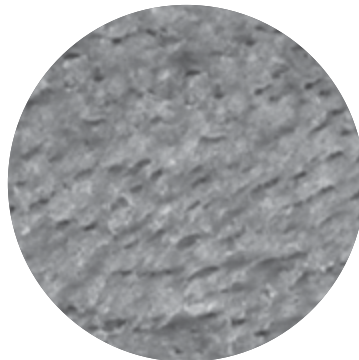

## Clinical Indications

- SINUS FLOOR AUGMENTATION
- SOCKET AND RIDGE PRESERVATION
- VERTICAL AND HORIZONTAL BONE AUGMENTATION
- BONE DEFECT FOLLOWING CYSTECTOMIES
- PERIODONTAL DEFECTS
- PERI-IMPLANT DEFECTS
- APICOECTOMIES

# xenobone Bovine Bone Graft Material

Bovine bone graft material for stability & Growth

## Essential & Technical Information:

- For your Convenience, cancellous xenogenic bone grafts are available in 3 application forms: vial, syringe or block. Vial & syringe are available in 3 granule sizes: 0.2-1mm, 0.5-1.2mm & 1.2-1.7mm
- **Safety first!** All products are sterilized by gamma radiation and are tested for virus inactivation, toxicity, biocompatibility and animal comparison.
- Storage conditions: dry conditions at ambient temperature of 15°-25° C.
- Each product is indicated for single use only!

REF. NO.	PRODUCT DESCRIPTION
25-0512	Alpha-Bio Tec xenobone™ 0.25g/0.6cc 0.5 - 1.2mm
05-0512	Alpha-Bio Tec xenobone™ 0.5g/1.2cc 0.5 - 1.2mm
10-0512	Alpha-Bio Tec xenobone™ 1g/2.3cc 0.5 - 1.2mm
20-0512	Alpha-Bio Tec xenobone™ 2.0g/4.5cc 0.5 - 1.2mm
25-1217	Alpha-Bio Tec xenobone™ 0.25g/0.75cc 1.2 - 1.7mm
05-1217	Alpha-Bio Tec xenobone™ 0.5g/1.5cc 1.2 - 1.7mm
10-1217	Alpha-Bio Tec xenobone™ 1.0g/3.0cc 1.2 - 1.7mm
20-1217	Alpha-Bio Tec xenobone™ 2.0g/6.0cc 1.2 - 1.7mm
25-0210	Alpha-Bio Tec xenobone™ 0.25g/0.45cc 0.2 - 1.0mm
05-0210	Alpha-Bio Tec xenobone™ 0.5g/0.8cc 0.2 - 1.0mm
10-0210	Alpha-Bio Tec xenobone™ 1.0g/1.5cc 0.2 - 1.0mm
20-0210	Alpha-Bio Tec xenobone™ 2.0g/3.0cc 0.2 - 1.0mm

BLK8812	Alpha-Bio Tec xenobone™ Block 8 x 8 x 12mm
BLK8825	Alpha-Bio Tec xenobone™ Block 8 x 8 x 25mm

S25-0512	Alpha-Bio Tec xenobone™ Syringe 0.25g/0.6cc 0.5-1.2mm
S05-0512	Alpha-Bio Tec xenobone™ Syringe 0.5g/1.2cc 0.5-1.2mm
S25-1217	Alpha-Bio Tec xenobone™ Syringe 0.25g/0.75cc 1.2 - 1.7mm
S05-1217	Alpha-Bio Tec xenobone™ Syringe 0.5g/1.5cc 1.2 - 1.7mm
S25-0210	Alpha-Bio Tec xenobone™ Syringe 0.25g/0.55cc 0.2 - 1.0mm
S05-0210	Alpha-Bio Tec xenobone™ Syringe 0.5g/1.1cc 0.2 - 1.0mm



**Vial containing graft particles**

🕒 Shelf-life: 3 years



**Block**

🕒 Shelf-life: 3 years



**Syringe**

🕒 Shelf-life: 2 years

# T-GEN COLLAGEN MEMBRANE

A Growing Success

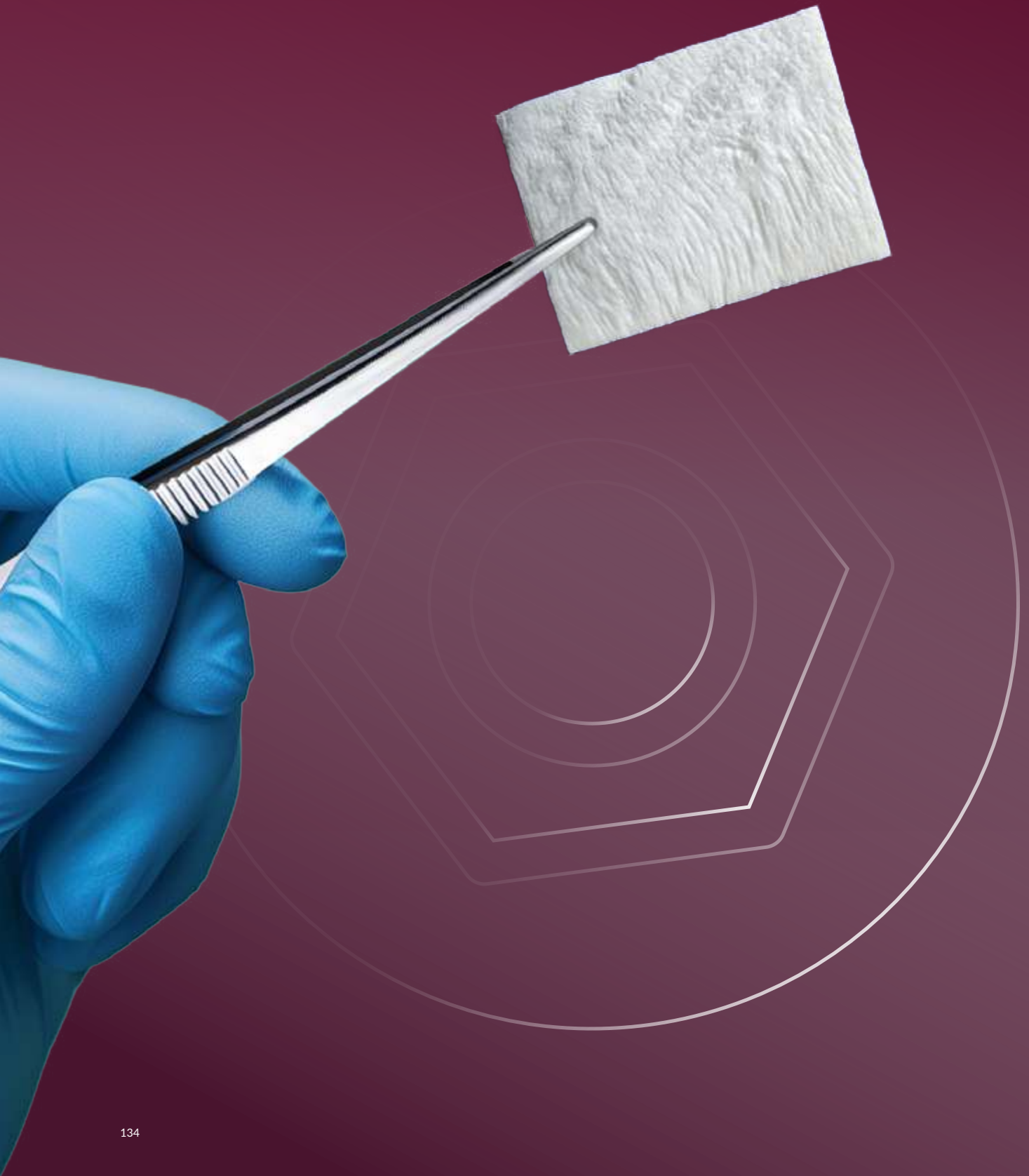

# T-GEN COLLAGEN MEMBRANE

## A Growing Success

Alpha-Bio's Graft Collagen Membrane is a reliable biodegradable (absorbable) barrier, made of purified collagen without cross-linking or chemical treatment, intended for use in a wide range of osseous regenerative indications.

### Clinical Indications

- Guided Bone Regeneration (GBR) procedures, e.g.:
  - Extraction socket preservation
  - Site preparation for implant placement
  - Alveolar ridge preservation
  - Fenestration & periodontal defects
  - Sinus floor augmentation
  - Apicoectomy
- Guided Tissue Regeneration (GTR) procedures

### Features & Benefits



#### High Stability

- Excellent tear resistance during surgery
- Prolonged barrier function and duration: degradation time approx. 3 months



#### Good Tissue Integration

- Fast blood supply to the defect
- Lower incidence of a dehiscence



#### Fast Hydration & Excellent Flexibility

- Adapts and contours to surfaces more firmly
- Good adaptation to the defect

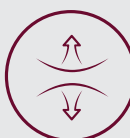

#### Easy Handling

- Easy to shape & adapt
- No need of distinction
- Good adaptation to various defects

# T-GEN COLLAGEN MEMBRANE

A Growing Success

## Ordering Information

REF. NO.	PRODUCT DESCRIPTION	SIZE
TG-1	TG-1 15*20mm	15 mm x 20 mm



REF. NO.	PRODUCT DESCRIPTION	SIZE
TG-2	TG-2 20*30mm	20 mm x 30 mm



REF. NO.	PRODUCT DESCRIPTION	SIZE
TG-3	TG-3 30*40mm	30 mm x 40 mm



All membranes are presented in actual size 1:1





# T-GEN COLLAGEN MEMBRANE

A Growing Success







**INDEX**

PRODUCT LIST

REF. NO.	CODE	PRODUCT DESCRIPTION	PAGE NO.
109	HS3	Healing Abutment L3.0mm	88
110	HS5	Healing Abutment L5.0mm	88
112	HSS3	Slim Healing Abutment L3.0mm	88
113	HSS5	Slim Healing Abutment L5.0mm	88
114	HSS4	Slim Healing Abutment L4.0mm	88
116	HS2	Healing Abutment L2.0mm	88
117	HS4	Healing Abutment L4.0mm	88
118	HS6	Healing Abutment L6.0mm	88
119	HS7	Healing Abutment L7.0mm	88
124	HS5-3	Healing Abutment D5.0 H3.0mm	88
125	HS5-5	Healing Abutment D5.0 H5.0mm	88
126	HS5.5-3	Healing Abutment D5.5 L3.0mm	88
127	HS5.5-5	Healing Abutment D5.5 H5.0mm	88
128	HS6-3	Healing Abutment D6.0 H3.0mm	88
129	HS6-5	Healing Abutment D6.0 H5.0mm	88
130	HS7-3	Healing Abutment D7.0 H3.0mm	88
1000	ICE	Implant Classical Esthetic Narrow D3.7mm L10mm	47
1001	ICE	Implant Classical Esthetic Narrow D3.7mm L11.5mm	47
1003	ICE	Implant Classical Esthetic Narrow D3.7mm L13mm	47
1010	ICE	Implant Classical Esthetic D3.75mm L10mm	47
1011	ICE	Implant Classical Esthetic D3.75mm L11.5mm	47
1013	ICE	Implant Classical Esthetic D3.75mm L13mm	47
1016	ICE	Implant Classical Esthetic D3.75mm L16mm	47
1018	ICE	Implant Classical Esthetic D3.75mm L8mm	47
1020	ICE	Implant Classical Esthetic D4.2mm L10mm	47
1021	ICE	Implant Classical Esthetic D4.2mm L11.5mm	47
1023	ICE	Implant Classical Esthetic D4.2mm L13mm	47
1026	ICE	Implant Classical Esthetic D4.2mm L16mm	47
1028	ICE	Implant Classical Esthetic D4.2mm L8mm	47
1030	ICE	Implant Classical Esthetic D4.65mm L10.0mm	47
1031	ICE	Implant Classical Esthetic D4.65mm L11.5mm	47
1033	ICE	Implant Classical Esthetic D4.65mm L13.0mm	47
1036	ICE	Implant Classical Esthetic D4.65mm L6.0mm	47
1038	ICE	Implant Classical Esthetic D4.65mm L8.0mm	47
1040	ICE	Implant Classical Esthetic D5.3mm L10mm	47
1041	ICE	Implant Classical Esthetic D5.3mm L11.5mm	47
1043	ICE	Implant Classical Esthetic D5.3mm L13mm	47
1046	ICE	Implant Classical Esthetic D5.3mm L6mm	47
1048	ICE	Implant Classical Esthetic D5.3mm L8mm	47
1056	ICE	Implant Classical Esthetic D4.2mm L6mm	47
1060	NICE	NICE D3.2mm L10mm	52
1061	NICE	NICE D3.2mm L11.5mm	52
1063	NICE	NICE D3.2mm L13mm	52
1066	NICE	NICE D3.2mm L16mm	52
1068	NICE	NICE D3.2mm L8mm	52

REF. NO.	CODE	PRODUCT DESCRIPTION	PAGE NO.
1260	DFI	Dual Fit Implant D3.75mm L10.0mm	38
1261	DFI	Dual Fit Implant D3.75mm L11.5mm	38
1263	DFI	Dual Fit Implant D3.75mm L13.0mm	38
1268	DFI	Dual Fit Implant D3.75mm L8.0mm	38
1270	DFI	Dual Fit Implant D4.2mm L10.0mm	38
1271	DFI	Dual Fit Implant D4.2mm L11.5mm	38
1273	DFI	Dual Fit Implant D4.2mm L13.0mm	38
1278	DFI	Dual Fit Implant D4.2mm L8.0mm	38
1280	DFI	Dual Fit Implant D3.3mm L10.0mm	38
1281	DFI	Dual Fit Implant D3.3mm L11.5mm	38
1283	DFI	Dual Fit Implant D3.3mm L13.0mm	38
1288	DFI	Dual Fit Implant D3.3mm L8.0mm	38
1290	DFI	Dual Fit Implant D5.0mm L10.0mm	38
1291	DFI	Dual Fit Implant D5.0mm L11.5mm	38
1293	DFI	Dual Fit Implant D5.0mm L13.0mm	38
1298	DFI	Dual Fit Implant D5.0mm L8.0mm	38
1300	SPIRAL	Spiral Implant D3.3mm L10.0mm	42
1301	SPIRAL	Spiral Implant D3.3mm L11.5mm	42
1303	SPIRAL	Spiral Implant D3.3mm L13.0mm	42
1306	SPIRAL	Spiral Implant D3.3mm L16.0mm	42
1308	SPIRAL	Spiral Implant D3.3mm L8.0mm	42
1330	SPIRAL	Spiral Implant D4.2mm L10.0mm	42
1331	SPIRAL	Spiral Implant D4.2mm L11.5mm	42
1333	SPIRAL	Spiral Implant D4.2mm L13.0mm	42
1336	SPIRAL	Spiral Implant D4.2mm L16.0mm	42
1338	SPIRAL	Spiral Implant D4.2mm L8.0mm	42
1340	SPIRAL	Spiral Implant D5.0mm L10.0mm	42
1341	SPIRAL	Spiral Implant D5.0mm L11.5mm	42
1343	SPIRAL	Spiral Implant D5.0mm L13.0mm	42
1346	SPIRAL	Spiral Implant D5.0mm L16.0mm	42
1348	SPIRAL	Spiral Implant D5.0mm L8.0mm	42
1350	SPIRAL	Spiral Implant D3.75mm L10.0mm	42
1351	SPIRAL	Spiral Implant D3.75mm L11.5mm	42
1353	SPIRAL	Spiral Implant D3.75mm L13.0mm	42
1356	SPIRAL	Spiral Implant D3.75mm L16.0mm	42
1358	SPIRAL	Spiral Implant D3.75mm L8.0mm	42
1360	SPIRAL	Spiral Implant D6.0mm L10.0mm	42
1361	SPIRAL	Spiral Implant D6.0mm L11.5mm	42
1363	SPIRAL	Spiral Implant D6.0mm L13.0mm	42
1368	SPIRAL	Spiral Implant D6.0mm L8.0mm	42
1820	DFI	DFI CS D3.75mm L10.0mm	38
1821	DFI	DFI CS D3.75mm L11.5mm	38
1823	DFI	DFI CS D3.75mm L13.0mm	38
1828	DFI	DFI CS D3.75mm L8.0mm	38
1830	DFI	DFI CS 4.2mm L10.0mm	38

REF. NO.	CODE	PRODUCT DESCRIPTION	PAGE NO.
1831	DFI	DFI CS D4.2mm L11.5mm	38
1833	DFI	DFI CS D4.2mm L13.0mm	38
1838	DFI	DFI CS D4.2mm L8.0mm	38
1840	DFI	DFI CS 5mm L10.0mm	38
1841	DFI	DFI CS D5mm L11.5mm	38
1843	DFI	DFI CS D5mm L13.0mm	38
1848	DFI	DFI CS D5mm L8.0mm	38
1900	MultiNeO	MultiNeO C D3.2mm L10.0mm	28
1901	MultiNeO	MultiNeO C D3.2mm L11.5mm	28
1903	MultiNeO	MultiNeO C D3.2mm L13.0mm	28
1906	MultiNeO	MultiNeO C D3.2mm L16.0mm	28
1908	MultiNeO	MultiNeO C D3.2mm L8.0mm	28
1920	MultiNeO	MultiNeO C D3.5mm L10.0mm	28
1921	MultiNeO	MultiNeO C D3.5mm L11.5mm	28
1923	MultiNeO	MultiNeO C D3.5mm L13.0mm	28
1926	MultiNeO	MultiNeO C D3.5mm L16.0mm	28
1928	MultiNeO	MultiNeO C D3.5mm L8.0mm	28
1930	MultiNeO	MultiNeO CS D3.75mm L10.0mm	28
1931	MultiNeO	MultiNeO CS D3.75mm L11.5mm	28
1933	MultiNeO	MultiNeO CS D3.75mm L13.0mm	28
1936	MultiNeO	MultiNeO CS D3.75mm L16.0mm	28
1938	MultiNeO	MultiNeO CS D3.75mm L8.0mm	28
1940	MultiNeO	MultiNeO CS D4.2mm L10.0mm	28
1941	MultiNeO	MultiNeO CS D4.2mm L11.5mm	28
1943	MultiNeO	MultiNeO CS D4.2mm L13.0mm	28
1946	MultiNeO	MultiNeO CS D4.2mm L16.0mm	28
1948	MultiNeO	MultiNeO CS D4.2mm L8.0mm	28
1950	MultiNeO	MultiNeO CS D5.0mm L10.0mm	28
1951	MultiNeO	MultiNeO CS D5.0mm L11.5mm	28
1953	MultiNeO	MultiNeO CS D5.0mm L13.0mm	28
1958	MultiNeO	MultiNeO CS D5.0mm L8.0mm	28
1960	MultiNeO	MultiNeO H D3.75mm L10.0mm	29
1961	MultiNeO	MultiNeO H D3.75mm L11.5mm	29
1963	MultiNeO	MultiNeO H D3.75mm L13.0mm	29
1966	MultiNeO	MultiNeO H D3.75mm L16.0mm	29
1968	MultiNeO	MultiNeO H D3.75mm L8.0mm	29
1970	MultiNeO	MultiNeO H D4.2mm L10.0mm	29
1971	MultiNeO	MultiNeO H D4.2mm L11.5mm	29
1973	MultiNeO	MultiNeO H D4.2mm L13.0mm	29
1976	MultiNeO	MultiNeO H D4.2mm L16.0mm	29
1978	MultiNeO	MultiNeO H D4.2mm L8.0mm	29
1980	MultiNeO	MultiNeO H D5.0mm L10.0mm	29
1981	MultiNeO	MultiNeO H D5.0mm L11.5mm	29
1983	MultiNeO	MultiNeO H D5.0mm L13.0mm	29
1988	MultiNeO	MultiNeO H D5.0mm L8.0mm	29

REF. NO.	CODE	PRODUCT DESCRIPTION	PAGE NO.
3301	TA-1.5-R-CHC	Temporary abutment Ti R 1.5 CHC	74
3302	TA-2.5-R-CHC	Temporary abutment Ti R 2.5 CHC	74
3303	TA-3.5-R-CHC	Temporary abutment Ti R 3.5 CHC	74
3304	TA-4.5-R-CHC	Temporary abutment Ti R 4.5 CHC	74
3306	SOTT-R-CHC	Open tray transfer short R CHC	73
3307	LOTT-AR-CHC	Open tray transfer Long AR CHC	73
3308	SOTT-AR-CHC	Open tray transfer short AR CHC	73
3309	TA-3N-AR-CHC	Temporary abutment Ti AR 3 narrow CHC	74
3311	TA-1.5-AR-CHC	Temporary abutment Ti AR 1.5 CHC	74
3312	TA-2.5-AR-CHC	Temporary abutment Ti AR 2.5 CHC	74
3313	TA-3.5-AR-CHC	Temporary abutment Ti AR 3.5 CHC	74
3314	TA-4.5-AR-CHC	Temporary abutment Ti AR 4.5 CHC	74
3315	TLA-L-CHC	Straight Ti abutment long CHC	75
3320	TLA-0.75-CHC	Straight Ti abutment 0.75 CHC	75
3321	TLA-1.5-CHC	Straight Ti abutment 1.5 CHC	75
3322	TLA-2.5-CHC	Straight Ti abutment 2.5 CHC	75
3323	TLA-3.5-CHC	Straight Ti abutment 3.5 CHC	75
3324	TLA-4.5-CHC	Straight Ti abutment 4.5 CHC	75
3327	TLASP-CHC	Snap transfer CHC	75
3341	HA-D4.2-1.5CHC	Healing abutment CHC 4.2 1.5	72
3342	HA-D4.2-2.5CHC	Healing abutment CHC 4.2 2.5	72
3343	HA-D4.2-3.5CHC	Healing abutment CHC 4.2 3.5	72
3344	HA-D4.2-4.5CHC	Healing abutment CHC 4.2 4.5	72
3345	HA-D4.2-5.5CHC	Healing abutment CHC 4.2 5.5	72
3350	NCTT-CHC	Closed tray transfer -CHC	73
3351	HA-D2.7-1.5CHC	Healing abutment CHC 2.7 1.5	72
3352	HA-D2.7-2.5CHC	Healing abutment CHC 2.7 2.5	72
3353	HA-D2.7-3.5CHC	Healing abutment CHC 2.7 3.5	72
3354	HA-D2.7-4.5CHC	Healing abutment CHC 2.7 4.5	72
3355	HA-D2.7-5.5CHC	Healing abutment CHC 2.7 5.5	72
3361	HA-D3.8-1.5CHC	Healing abutment CHC 3.8 1.5	72
3362	HA-D3.8-2.5CHC	Healing abutment CHC 3.8 2.5	72
3363	HA-D3.8-3.5CHC	Healing abutment CHC 3.8 3.5	72
3364	HA-D3.8-4.5CHC	Healing abutment CHC 3.8 4.5	72
3365	HA-D3.8-5.5CHC	Healing abutment CHC 3.8 5.5	72
3371	NTLA20-H1.5-CHC	Angled Ti abutment 20° 1.5 CHC	75
3372	NTLA20-H2.5-CHC	Angled Ti abutment 20° 2.5 CHC	75
3373	NTLA20-H3.5-CHC	Angled Ti abutment 20° 3.5 CHC	75
3381	NTLA10-H1.5-CHC	Angled Ti abutment 10° 1.5 CHC	75
3382	NTLA10-H2.5-CHC	Angled Ti abutment 10° 2.5 CHC	75
3383	NTLA10-H3.5-CHC	Angled Ti abutment 10° 3.5 CHC	75
3401	HA-D4-CH1.5CS	Healing Abutment D4.0 CH1.5 mm CS	69
3402	HA-D4-CH2.5CS	Healing Abutment D4.0 CH2.5 mm CS	69
3403	HA-D4-CH3.5CS	Healing Abutment D4.0 CH3.5 mm CS	69
3404	HA-D4-CH4.5CS	Healing Abutment D4.0 CH4.5 mm CS	69

REF. NO.	CODE	PRODUCT DESCRIPTION	PAGE NO.
3405	HA-D4-CH5.5CS	Healing Abutment D4.0 CH5.5 mm CS	69
3407	HA-4.9-1.5-CS	Healing Abutment D4.9 CH1.5 mm CS	69
3408	HA-4.9-2.5-CS	Healing Abutment D4.9 CH2.5 mm CS	69
3409	HA-4.9-3.5-CS	Healing Abutment D4.9 CH3.5 mm CS	69
3410	HA-4.9-4.5-CS	Healing Abutment D4.9 CH4.5 mm CS	69
3411	HA-4.9-5.5-CS	Healing Abutment D4.9 CH5.5 mm CS	69
3412	HA-D6.2-CH1.5-CS	Healing Abutment D6.2 CH1.5 mm CS	69
3413	HA-D6.2-CH2.5-CS	Healing Abutment D6.2 CH2.5 mm CS	69
3450	SCTT-CS	Short Closed Tray Transfer CS	69
3451	LCTT-CS	Long Closed Tray Transfer CS	69
3455	SOTT-CS	Short Open Tray Transfer CS	69
3456	LOTT-CS	Long Open Tray Transfer CS	69
3459	IA-CS	Implant Analog - CS	59
3501	TLA-H1.5CS	Straight Abutment CH1.5mm CS	69
3502	TLA-H2.5CS	Straight Abutment CH2.5mm CS	69
3503	TLA-H3.5CS	Straight Abutment CH3.5mm CS	69
3504	TLA-H4.5CS	Straight Abutment CH4.5mm CS	69
3510	STLA-CS	Abutment Screw - CS	59
3511	TLA15°H1.5CS	Angled Abutment 15° CH1.5 CS	69
3512	TLA15°H2.5CS	Angled Abutment 15° CH2.5 CS	69
3514	TLA25°H1.5CS	Angled Abutment 25° CH1.5 CS	69
3515	TLA25°H2.5CS	Angled Abutment 25° CH2.5 CS	69
3532	TA-AR-CS	Temporary Titanium Abutment AR CS	69
3533	TA-R-CS	Temporary Titanium Abutment R CS	69
3710	AK-0.75 - CS	AlphaLoC Kit H 0.75 mm CS	68
3711	AK-1.5 - CS	AlphaLoC Kit H 1.5 mm CS	68
3712	AK-2.5 - CS	AlphaLoC Kit H 2.5 mm CS	68
3713	AK-3.5 - CS	AlphaLoC Kit H 3.5 mm CS	68
3714	AK-4.5 - CS	AlphaLoC Kit H 4.5 mm CS	68
3801	ITD2.5S-CS	Implant Driver Short 2.5mm CS	112
3803	ITD2.5L-CS	Implant Driver Long 2.5mm CS	112
3804	IT2.5SM-CS	Motor Mount Driver Short 2.5mm CS	112
3805	IT2.5LM-CS	Motor Mount Driver Long 2.5mm CS	112
3806	MITD2.5-CS	Manual Implant Driver 2.5mm CS	112
3832	TB-0.75-AR-CS	CAD/CAM Titanium Base H0.75 mm - CS-AR	65
3833	TB-0.75-R-CS	CAD/CAM Titanium Base H0.75 mm CS-R	65
3837	IOSB-LCS	Intraoral Scan Body CSL	65
3838	AN-PM-CS	Analog for printed model CS	65
3840	TB-1.5-AR-CS	CAD/CAM Titanium Base H1.5 mm - CS - AR	65
3841	TB-1.5-R-CS	CAD/CAM Titanium Base H1.5 mm CS - R	65
3842	TB-2.5-AR-CS	CAD/CAM Titanium Base H2.5 mm - CS - AR	65
3843	TB-2.5-R-CS	CAD/CAM Titanium Base H2.5 mm CS - R	65
3854	BA-PF-CS	PreFace Compatible Blank abutment CS	65
3855	WBA-PF-CS	Wide PreFace Compatible Blank abutment CS	65
3856	CSTB-CS-SI	Sirona CAD/CAM Ti Base-CS	65



REF. NO.	CODE	PRODUCT DESCRIPTION	PAGE NO.
3857	CSSP-CS-SI	Sirona CAD/CAM Scan Post-CS	65
3862	AU17-1.5CS	Alpha Universe 17° H1.5mm CS	62
3863	AU17-2.5CS	Alpha Universe 17° H2.5mm CS	62
3864	AU17-3.5CS	Alpha Universe 17° H3.5mm CS	62
3867	AU30-1.5CS	Alpha Universe 30° H1.5mm CS	62
3868	AU30-2.5CS	Alpha Universe 30° H2.5mm CS	62
3869	AU30-3.5CS	Alpha Universe 30° H3.5mm CS	62
3870	TCT 0.75-CS	Alpha Universe straight H0.75mm CS	62
3871	TCT 1.5-CS	Alpha Universe straight H1.5mm CS	62
3872	TCT 2.5-CS	Alpha Universe straight H2.5mm CS	62
3873	TCT 3.5-CS	Alpha Universe straight H3.5mm CS	62
3874	TCT 4.5-CS	Alpha Universe straight H4.5mm CS	62
3875	TCT 5.5-CS	Alpha Universe straight H5.5mm CS	62
3876	HBC H0.75 CS	HBC H0.75 mm CS	62
3877	HBC H1.5 CS	HBC H1.5 mm CS	62
3878	HBC H2.5 CS	HBC H2.5 mm CS	62
3883	IOSB-TCT-N-R	Scan Body - Screw Retained TCT-N-R	64, 78, 98
3901	TA-1.5-R-CS	Temporary abutment Ti R 1.5 CS	60
3902	TA-2.5-R-CS	Temporary abutment Ti R 2.5 CS	60
3903	TA-3.5-R-CS	Temporary abutment Ti R 3.5 CS	60
3904	TA-4.5-R-CS	Temporary abutment Ti R 4.5 CS	60
3910	TLACAP_10	Plastic cap for closed tray transfer package (10)	59
3911	TA-1.5-AR-CS	Temporary abutment Ti AR 1.5 CS	60
3912	TA-2.5-AR-CS	Temporary abutment Ti AR 2.5 CS	60
3913	TA-3.5-AR-CS	Temporary abutment Ti AR 3.5 CS	60
3914	TA-4.5-AR-CS	Temporary abutment Ti AR 4.5 CS	60
3915	TA-3N-R-CS	Temporary abutment Ti AR 3 narrow CS	60
3920	TLA-0.75-CS	Straight Ti abutment 0.75 CS	61
3921	TLA-1.5-CS	Straight Ti abutment 1.5 CS	61
3922	TLA-2.5-CS	Straight Ti abutment 2.5 CS	61
3923	TLA-3.5-CS	Straight Ti abutment 3.5 CS	61
3924	TLA-4.5-CS	Straight Ti abutment 4.5 CS	61
3925	TLASP_CS	Snap transfer CS	61
3926	TLA-L-CS	Straight Ti abutment long CS	61
3931	HA-D3.5-1.5CS	Healing abutment CS 3.5 1.5	58
3932	HA-D3.5-2.5CS	Healing abutment CS 3.5 2.5	58
3933	HA-D3.5-3.5CS	Healing abutment CS 3.5 3.5	58
3934	HA-D3.5-4.5CS	Healing abutment CS 3.5 4.5	58
3935	HA-D3.5-5.5CS	Healing abutment CS 3.5 5.5	58
3941	HA-D4.3-1.5CS	Healing abutment CS 4.3 1.5	58
3942	HA-D4.3-2.5CS	Healing abutment CS 4.3 2.5	58
3943	HA-D4.3-3.5CS	Healing abutment CS 4.3 3.5	58
3944	HA-D4.3-4.5CS	Healing abutment CS 4.3 4.5	58
3945	HA-D4.3-5.5CS	Healing abutment CS 4.3 5.5	58
3951	HA-D5.7-1.5CS	Healing abutment CS 5.7 1.5	58

REF. NO.	CODE	PRODUCT DESCRIPTION	PAGE NO.
3952	HA-D5.7-2.5CS	Healing abutment CS 5.7 2.5	58
3953	HA-D5.7-3.5CS	Healing abutment CS 5.7 3.5	58
3954	HA-D5.7-4.5CS	Healing abutment CS 5.7 4.5	58
3955	HA-D5.7-5.5CS	Healing abutment CS 5.7 5.5	58
3961	NSCTT-CS	Closed tray transfer short-CS	59
3963	LOTT-R-CS	Open tray transfer Long R CS	59
3964	SOTT-R-CS	Open tray transfer short R CS	59
3965	LOTT-AR-CS	Open tray transfer Long AR CS	59
3966	SOTT-AR-CS	Open tray transfer short AR CS	59
3971	NTLA10-H1.5CS	Angled Ti abutment 10° 1.5 CS	61
3972	NTLA10-H2.5CS	Angled Ti abutment 10° 2.5 CS	61
3973	NTLA10-H3.5CS	Angled Ti abutment 10° 3.5 CS	61
3981	NTLA20-H1.5CS	Angled Ti abutment 20° 1.5 CS	61
3982	NTLA20-H2.5CS	Angled Ti abutment 20° 2.5 CS	61
3983	NTLA20-H3.5CS	Angled Ti abutment 20° 3.5 CS	61
4012	USH	Universal Square Ratchet Head	123
4052	HHS 1.25	Hand Hex Screw Driver 1.25mm	114
4053	HHSS 1.25	Short Hand Hex Screw Driver 1.25mm	114, 123
4055	HTD 1.25	Hex Driver 1.25mm	114
4056	HTD 1.25 S	Short Hex Driver 1.25mm	114, 123
4057	HTD 1.5	Short Hex Driver 1.5mm	114
4058	HTD 1.5S	Pro Short Hex Driver 1.5mm	114
4059	HHS 1.5	Pro Hand Hex Screw Driver 1.5mm	114
4060	HHL 1.5	Pro Hand Hex Long Screw Driver 1.5mm	114
4061	HTD 1.25L	Long Hex Driver 1.25mm	114
4080	PDG	Parallel Depth Guide	115
4081	PDGS	Short Parallel Depth Guide	115
4082	PG	Drilling Parallel Guide	115
4100	IDG	Implant Depth Probe	115
4140	G-ITDL2.5	Implant Grip Driver Long 2.5mm	113
4141	G-ITDM2.5	Implant Grip Driver Standard 2.5mm	113
4142	G-ITDS2.5	Implant Grip Driver Short 2.5mm	113
4143	GITL2.5/1.25	Motor Mount Grip Driver Long 2.5/1.25mm	113
4145	GITS2.5/1.25	Motor Mount Grip Driver Short 2.5/1.25mm	113
4146	MITD2.5-IH	Implant Hand Driver 2.5mm IH	113
4147	MITD2.1-CHC	Implant Hand Driver 2.1mm CHC	112
4165	HT 1.25M	Motor Mount Hex Driver 1.25mm	114
4168	HT1.5	Pro Motor Mount Hex Driver 1.5mm	114
4220	SDH	Surgical Screwdriver	115
4240	DX	Drill Extension L17.5mm	111
4304	RB3	Round Bur D3.0mm	111
4550	BD2.0	Alpha Straight Drill_D2.0	109
4551	BD2.4	Alpha Straight Drill_D2.4	109
4552	BD2.8	Alpha Straight Drill_D2.8	109
4553	BD3.0	Alpha Straight Drill_D3.0	109

REF. NO.	CODE	PRODUCT DESCRIPTION	PAGE NO.
4554	BD3.2	Alpha Straight Drill_D3.2	109
4555	BD3.65	Alpha Straight Drill_D3.65	109
4556	BD4.1	Alpha Straight Drill_D4.1	109
4557	BD4.5	Alpha Straight Drill_D4.5	109
4558	BD4.8	Alpha Straight Drill_D4.8	109
4559	BD5.2	Alpha Straight Drill_D5.2	109
4560	BD5.8	Alpha Straight Drill_D5.8	109
4561	DS-A-L6	Alpha Drill Stopper A-D2.0-2.4 L6	110
4562	DS-A-L8	Alpha Drill Stopper A-D2.0-2.4 L8	110
4563	DS-A-L10	Alpha Drill Stopper A-D2.0-2.4 L10	110
4564	DS-A-L11.5	Alpha Drill Stopper A-D2.0-2.4 L11.5	110
4565	DS-A-L13	Alpha Drill Stopper A-D2.0-2.4 L13	110
4566	DS-B-L6	Alpha Drill Stopper B-D2.8-3.0 L6	110
4567	DS-B-L8	Alpha Drill Stopper B-D2.8-3.0 L8	110
4568	DS-B-L10	Alpha Drill Stopper B-D2.8-3.0 L10	110
4569	DS-B-L11.5	Alpha Drill Stopper B-D2.8-3.0 L11.5	110
4570	DS-B-L13	Alpha Drill Stopper B-D2.8-3.0 L13	110
4572	URT	Universal Torque Ratchet 10-45Ncm	115
4573	DS-C-L6	Alpha Drill Stopper C-D3.2-3.65 L6	110
4574	DS-C-L8	Alpha Drill Stopper C-D3.2-3.65 L8	110
4575	DS-C-L10	Alpha Drill Stopper C-D3.2-3.65 L10	110
4576	DS-C-L11.5	Alpha Drill Stopper C-D3.2-3.65 L11.5	110
4577	DS-C-L13	Alpha Drill Stopper C-D3.2-3.65 L13	110
4578	DS-D-L6	Alpha Drill Stopper D-D4.1-4.5 L6	110
4579	DS-D-L8	Alpha Drill Stopper D-D4.1-4.5 L8	110
4580	DS-D-L10	Alpha Drill Stopper D-D4.1-4.5 L10	110
4581	DS-D-L11.5	Alpha Drill Stopper D-D4.1-4.5 L11.5	110
4582	DS-D-L13	Alpha Drill Stopper D-D4.1-4.5 L13	110
4590	BSD2.0/2.4	Alpha Step Drill_2.0/2.4	109
4592	BSD2.4/2.8	Alpha Step Drill_2.4/2.8	109
4593	BSD2.8/3.0	Alpha Step Drill_2.8/3.0	109
4594	BSD2.8/3.2	Alpha Step Drill_2.8/3.2	109
4595	BSD3.2/3.65	Alpha Step Drill_3.2/3.65	109
4596	BSD3.65/4.1	Alpha Step Drill_3.65/4.1	109
4597	BSD4.1/4.5	Alpha Step Drill_4.1/4.5	109
4598	BSD4.5/4.8	Alpha Step Drill_4.5/4.8	109
4599	BSD4.8/5.2	Alpha Step Drill_4.8/5.2	109
4612	SSK	Stopper Surgical Kit	110
4672	CS	Countersink Drill D2.7-5.9mm	111
4867	AK0.5	AlphaLoC Kit 0.5mm	102
4868	AK1	AlphaLoC Kit 1mm	102
4869	AK2	AlphaLoC Kit 2mm	102
4870	AK3	AlphaLoC Kit 3mm	102
4871	AK4	AlphaLoC Kit 4mm	102
4872	AK5	AlphaLoC Kit 5mm	102

REF. NO.	CODE	PRODUCT DESCRIPTION	PAGE NO.
4875	AMPP	AlphaLoC Male Processing Package	68, 82, 102
4876	AMSTR	AlphaLoC Male-Strong violate units (X4)	68, 82, 102
4877	AMSTA	AlphaLoC Male-Standard white units (X4)	68, 82, 102
4878	AMSOF	AlphaLoC Male-Soft pink units (X4)	68, 82, 102
4879	AMESO	AlphaLoC Male-Extra Soft yellow (X4)	68, 82, 102
4882	AML	AlphaLoC Male-Laboratory black units(X4)	68, 82, 102
4883	ABOS	AlphaLoC Block Out Spacer	68, 82, 102
4884	AIC	AlphaLoC Impression Coping (X4)	68, 82, 102
4885	AFA	AlphaLoC Female Analog (X4)	68, 82, 102
4886	AIT	AlphaLoC Insertion Tool	68, 82, 102
4887	AET	AlphaLoC Extraction Tool	68, 82, 102
4940	DRT4	Trephine Drill D4.0mm	111
4950	DRT5	Trephine Drill D5.0mm	111
4961	CCTB-0.75-AR-IH	CAD/CAM Titanium Base 0.75 IH Engaged	99
4962	CCTB-1.5-AR-IH	CAD/CAM Titanium Base 1.5 IH Engaged	99
4963	CCTB-2.5-AR-IH	CAD/CAM Titanium Base 2.5 IH Engaged	99
4964	CCTB-0.75-R-IH	CAD/CAM Titanium Base 0.75 IH Non Engaged	99
4965	CCTB-1.5-R-IH	CAD/CAM Titanium Base 1.5 IH Non Engaged	99
4966	CCTB-2.5-R-IH	CAD/CAM Titanium Base 2.5 IH Non Engaged	99
4980	CCTB-IH-SI	Sirona CAD/CAM Ti Base	100
4982	CCTB-CHC-SI	Sirona CAD/CAM Ti Base-CHC	79
4984	CCSP-IH-SI	Sirona CAD/CAM Scan Post	100
4985	CCSP-CHC-SI	Sirona CAD/CAM Scan Post-CHC	79
4988	BA-PF-IH	Premilled blank IH	99
4989	WBA-PF-IH	Premilled blank IH	99
4990	BA-PF-CHC	PreFace Compatible Blank abutment - CHC	79
4994	S-DM-SR	Screw for direct mounting on screw retain	64, 78, 98
5003	IOSB-TCT-N	Intraoral Scan Body - Screw Retained TCT-N	64, 78, 98
5007	WCCTB	Wide CAD/CAM Ti Base	99
5008	WCCTB-R	Wide CAD/CAM Ti Base Non-Engaging	99
5019	SB-IH	Scan Abutment - Internal Hex implants	99
5021	SB-CHC	Scan Abutment - CHC implants	79
5028	TAC-TCT-N	CAD/CAM Adhesive coping TCT-N	64, 78, 98
5029	TAC-TCT-N-R	CAD/CAM Adhesive coping - TCT-N-R	64, 78, 98
5030	TLA	Straight Titanium Abutment	93
5031	ETLA	Esthetic Straight Titanium Abutment	93
5039	AC-R-4.5	CADCAM Adhesive coping R 4.5	64, 78, 98
5040	PLA	Straight Plastic Abutment Anti Rotation	95
5041	PLA-R	Straight Plastic Abutment Rotation	95
5060	HLT	Closed Tray Transfer	90
5061	HLTO	Open Tray Transfer	90
5062	HLTLS	Slim Closed Tray Transfer	90
5080	IA	Implant Analog	95
5090	TLA15	Angled Titanium Abutment °15	94
5091	TLA15B	Angled Titanium Abutment °15 with Shoulder	94

REF. NO.	CODE	PRODUCT DESCRIPTION	PAGE NO.
5092	TLAL15	Long Angled Titanium Abutment 15°	94
5094	ETLAL15	Esthetic Long Angled Titanium Abutment 15°	94
5098	TLA15BB	Long Angled Titanium Abutment 15° with Shoulder	94
5110	RS	Retrieval Screw	59, 95
5121	STLAT	Torqfit Abutment Screw	95
5122	STLAS	Short Titanium Abutment Screw L8.3mm	95
5127	STLASH	Titanium Abutment Screw L7.6mm	95
5130	TLA25	Angled Titanium Abutment 25°	94
5131	ETLA25	Esthetic Angled Titanium Abutment 25°	94
5134	TLAL25	Titanium Lock Abutment 25° Long	94
5136	TLA35	Titanium Lock Abutment Angled 35°	94
5140	TLAL	Long Straight Titanium Abutment	93
5150	TLAS	Slim Straight Titanium Abutment	93
5155	ETLAS	Esthetic Slim Long Straight Titanium Abutment	93
5170	HLTS	Short Closed Tray Transfer	90
5171	HLTOS	Short Open Tray Transfer	90
5182	TLAO2	Omni Titanium Abutment Cuff H2.0mm	93
5200	TLAC-AR	Temporary Titanium Abutment Anti Rotation	89
5211	BTT-N	Pro Analog for TCT-N	63, 73, 77, 95, 97
5216	TTA-N	Pro Temporary Titanium Abutment for TCT-N	63, 77, 97
5217	PST-N-AR	Pro Burnout Anti Rotation Sleeve for TCT-N	63, 77, 97
5218	PST-N	Pro Burnout Sleeve for TCT-N	63, 77, 97
5220	TLAC-R	Temporary Titanium Abutment Rotation	89
5221	TCT0.5-N	Pro Tapered Connection Abutment L 0.5mm	96
5222	TCT1.5-N	Pro Tapered Connection Abutment L 1.5mm	96
5223	TCT2.5-N	Pro Tapered Connection Abutment L 2.5mm	96
5231	TST-N	Pro Open Tray Transfer for TCT-N/AUC-TCT-N	63, 77, 97
5235	TS-N	Pro Close Tray Transfer for TCT-N/TSA-N abutment	63, 77, 97
5236	HCT4-N	Pro Healing Abutment L4mm for TCT-N/AUC-TCT-N	63, 77, 97
5237	HCT6-N	Pro Healing Abutment L6mm for TCT-N/AUC-TCT-N	63, 77, 97
5242	TCT-N-0.75-CHC	Pro Tapered Connection Abutment L 0.75mm N CHC	76
5243	TCT-N-1.5-CHC	Pro Tapered Connection Abutment L 1.5mm N CHC	76
5244	TCT-N-2.5-CHC	Pro Tapered Connection Abutment L 2.5mm N CHC	76
5245	TCT-N-3.5-CHC	Pro Tapered Connection Abutment L 3.5mm N CHC	76
5246	TCT-N-4.5-CHC	Pro Tapered Connection Abutment L 4.5mm N CHC	76
5247	TCT-N-5.5-CHC	Pro Tapered Connection Abutment L 5.5mm N CHC	76
5248	TST-N-R	Pro Open Tray Transfer (R) for TCT-N/AUC-TCT-N	63, 77, 97
5252	TCT3.5-N	Pro Tapered Connection Abutment L 3.5mm	96
5253	TCT4.5-N	Pro Tapered Connection Abutment L4.5mm	96
5254	TCT5.5-N	Pro Tapered Connection Abutment L 5.5mm	96
5280	IA5	Implant Analog D5.0mm	95
5340	TLAW	Wide Straight Titanium Abutment	93
5352	ETLASP1	Simply Esthetic Straight Titanium Abutment H1mm	92
5353	ETLASP2	Simply Esthetic Straight Titanium Abutment H2mm	92
5354	ETLASP3	Simply Esthetic Straight Titanium Abutment H3mm	92

REF. NO.	CODE	PRODUCT DESCRIPTION	PAGE NO.
5355	ETLASP4	Simply Esthetic Straight Titanium Abutment H4mm	92
5362	TLAO4	Omni Titanium Abutment Cuff H4.0mm	93
5364	HTLASP	Simply Close Tray Plastic Transfer	69, 92
5366	TLASP1	Simply Straight Titanium Abutment Cuff H1.0mm	92
5367	TLASP2	Simply Straight Titanium Abutment Cuff H2.0mm	92
5368	TLASP3	Simply Straight Titanium Abutment Cuff H3.0mm	92
5369	TLASP4	Simply Straight Titanium Abutment Cuff H4.0mm	92
5403	TLASSP	Slim Titanium Abutment with Short Platform	93
5410	EAA515	Short Esthetic Anatomic Abutment 15°	94
5411	EAA15	Esthetic Anatomic Abutment 15°	94
5412	EAAH15	High Esthetic Anatomic Abutment 15°	94
5413	EAA525	Short Esthetic Anatomic Abutment 25°	94
5414	EAA25	Esthetic Anatomic Abutment 25°	94
5415	EAAH25	High Esthetic Anatomic Abutment 25°	94
5416	TPA 1	Straight temporary PEEK Abutment H 1.0	89
5417	TPA 2	Straight temporary PEEK abutment H 2.0	89
5418	TPA 3	Straight temporary PEEK abutment H 3.0	89
5419	TPA15-1	Temporary PEEK abutment 15° H1.0	89
5420	TPA15-2	Temporary PEEK abutment 15° H 2.0	89
5421	TPA15-3	Temporary PEEK abutment 15° H 3.0	89
5422	TPA25-1	Temporary PEEK abutment 25° H 1.0	89
5423	TPA25-2	Temporary PEEK abutment 25° H 2.0	89
5432	AU17-1.5IH	Alpha Universe 17° H1.5mm IH	96
5433	AU17-2.5IH	Alpha Universe 17° H2.5mm IH	96
5434	AU17-3.5IH	Alpha Universe 17° H3.5mm IH	96
5437	AU30-1.5IH	Alpha Universe 30° H1.5mm IH	96
5438	AU30-2.5IH	Alpha Universe 30° H2.5mm IH	96
5439	AU30-3.5IH	Alpha Universe 30° H3.5mm IH	96
5450	CCTB-0.75-AR-CHC	CAD/CAM Titanium Base 0.75 CHC Engaged	79
5451	CCTB-1.5-AR-CHC	CAD/CAM Titanium Base 1.5 CHC Engaged	79
5452	CCTB-2.5-AR-CHC	CAD/CAM Titanium Base 2.5 CHC Engaged	79
5453	CCTB-0.75-R-CHC	CAD/CAM Titanium Base 0.75 CHC Non Engaged	79
5454	CCTB-1.5-R-CHC	CAD/CAM Titanium Base 1.5 CHC Non Engaged	79
5455	CCTB-2.5-R-CHC	CAD/CAM Titanium Base 2.5 CHC Non Engaged	79
5456	AN-PM-TCT-N	CAD/CAM TCT-N Analog for printed model	64, 78, 98
5457	AN-PM-IH	CAD/CAM IH Analog for printed model	95, 99
5458	AN-PM-CHC	CAD/CAM CHC Analog for printed model	79
5459	APMT_IH_CS	Analog Printed Model insertion tool CS/IH	64, 78, 98
5460	APMT_CHC	Analog Printed Model insertion tool CHC	79
5462	STLA_IH_60_DEG	IH screw 60 deg contact	95
5463	STLA_CHC_60_DEG	CHC screw 60 deg contact	73
5464	SiTB_IH_1.5	Sirona CAD/CAM Titanium Base 1.5 IH	100
5465	SiTB_IH_2.5	Sirona CAD/CAM Titanium Base 2.5 IH	100
5466	SiTB_IH_3.5	Sirona CAD/CAM Titanium Base 3.5 IH	100
5467	SiTB_CHC_1.5	Sirona CAD/CAM Titanium Base 1.5 CHC	79

REF. NO.	CODE	PRODUCT DESCRIPTION	PAGE NO.
5468	SiTB_CHC_2.5	Sirona CAD/CAM Titanium Base 2.5 CHC	79
5469	SiTB_CHC_3.5	Sirona CAD/CAM Titanium Base 3.5 CHC	79
5470	SiTB_CS_1.5	Sirona CAD/CAM Titanium Base 1.5 CS	65
5471	SiTB_CS_2.5	Sirona CAD/CAM Titanium Base 2.5 CS	65
5472	SiTB_CS_3.5	Sirona CAD/CAM Titanium Base 3.5 CS	65
5475	AHD-S	Manual TX driver angled - Standard	116
5476	ARD-L	Ratchet TX driver angled - Long	116
5477	AMD	Motor TX driver angled- Standard	116
5478	VHD-S	Manual TX driver vertical- Standard	117
5479	VHD-L	Manual TX driver vertical - Long	117
5485	OB-TX-S-CS	TX Screw - CS Short	67
5486	OB-TX-L-CS	TX screw- CS Long	67
5495	VMD-L	Motor TX driver vertical -Long	117
5496	VRD-SD	Ratchet TX driver vertical- Standard	117
5497	VRD-L	Ratchet TX driver vertical- Long	117
5498	VMD	Motor TX driver vertical- Standard	117
5501	OB-TX-L-CHC	TX screw -CHC Long	81
5507	OB-TX-S-CHC	TX screw- CHC Short	81
5530	OB4.7-0.75-CHC	Omnibase 0.75 -CHC Short	80
5531	OB4.7-1.5-CHC	Omnibase 1.5 -CHC Short	80
5532	OB4.7-2.5-CHC	Omnibase 2.5 -CHC Short	80
5533	OB4.7-3.5-CHC	Omnibase 3.5 -CHC Short	80
5534	OB4.7-4.5-CHC	Omnibase 4.5 -CHC Short	80
5540	OB8-0.75-CHC	Omnibase 0.75 -CHC Long	80
5541	OB8-1.5-CHC	Omnibase 1.5 -CHC Long	80
5542	OB8-2.5-CHC	Omnibase 2.5 -CHC Long	80
5543	OB8-3.5-CHC	Omnibase 3.5 -CHC Long	80
5544	OB8-4.5-CHC	Omnibase 4.5 -CHC Long	80
5546	AHD-L	Manual TX driver angled -Long	116
5547	AMD-L	Motor TX driver angled-Long	116
5548	ARD-SD	Ratchet TX driver angled- Standard	116
6040	HBC 0.5	Hex Base Connection L 0.5mm	96
6041	HBC 1.5	Hex Base Connection L 1.5mm	96
6042	HBC 2.5	Hex Base Connection L 2.5mm	96
6092	SF-N	Pro Fixation Screw SF-N	63, 77, 78, 97, 98
6093	SFT-N	Pro Fixation Torqfit Screw SFT-N	63, 77, 78, 97, 98
6210	TB 2	Titanium Ball Abutment L2.0mm	103
6220	TB 4	Titanium Ball Abutment L4.0mm	103
6240	H	Metal Housing for Ball Attachment	83
6250	NC	Standard Nylon Cap	83
6251	NCT	Nylon Cap with Titanium Ring	83
6253	NCA	Soft Nylon Cap	83
6260	TB 0.5	Titanium Ball Abutment L 0.5mm	103
6270	TB 5	Titanium Ball Abutment L5.0mm	103
6280	TB 3	Titanium Ball Abutment L3.0mm	103

REF. NO.	CODE	PRODUCT DESCRIPTION	PAGE NO.
6290	TB 6	Titanium Ball Abutment L6.0mm	103
6304	TBAA2	Angled Titanium Side Ball Abutment L2.0mm	103
6306	TBAA3	Angled Titanium Side Ball Abutment L3.0mm	103
7301	ITD2.1L-CHC	Implant Driver Long 2.1mm CHC	112
7302	ITD2.1S-CHC	Implant Driver Short 2.1mm CHC	112
7303	IT2.1LM -CHC	Motor Mount Driver Long 2.1mm CHC	112
7304	IT2.1SM -CHC	Motor Mount Driver Short 2.1mm CHC	112
7305	ITD2.1-CHC	Implant Driver Standard 2.1mm CHC	112
7311	HSD3.4-2-CHC	Healing Abutment D3.4 L2 CHC	84
7312	HSD3.4-3-CHC	Healing Abutment D3.4 L3 CHC	84
7313	HSD3.4-5-CHC	Healing Abutment D3.4 L5 CHC	84
7315	HSD3.8-2-CHC	Healing Abutment D3.8 L2 CHC	84
7316	HSD3.8-3-CHC	Healing Abutment D3.8 L3 CHC	84
7317	HSD3.8-5-CHC	Healing Abutment D3.8 L5 CHC	84
7319	HSD4.2-2-CHC	Healing Abutment D4.2 L2 CHC	84
7320	HSD4.2-3-CHC	Healing Abutment D4.2 L3 CHC	84
7321	HSD4.2-5-CHC	Healing Abutment D4.2 L5 CHC	84
7333	HLTS-CHC	Closed Tray Transfer CHC	84
7335	HLTO-CHC	Long Open Tray Transfer CHC	84
7338	IA-CHC	Implant Analog CHC	73
7345	STLA-CHC	Abutment Screw CHC	85
7350	ETLASP1-CHC	Esthetic Simply Straight Abutment H1.0mm CHC	84
7351	ETLASP2-CHC	Esthetic Simply Straight Abutment H2.0mm CHC	84
7352	ETLASP3 -CHC	Esthetic Simply Straight Abutment H3.0mm CHC	84
7353	ETLASP4-CHC	Esthetic Simply Straight Abutment H4.0mm CHC	84
7356	ETLAS3.2-CHC	Esthetic Standard Slim Abutment D3.2 CHC	84
7357	ETLAS3.6-CHC	Esthetic Standard Abutment D3.6 CHC	84
7358	TLAS4.0-CHC	Standard Abutment D4.0 CHC	84
7360	ETLA15-CHC	Esthetic Angled Titanium Abutment 15° CHC	85
7361	ETLAL15-CHC	Esthetic Angled Long Titanium Abutment 15° CHC	85
7362	ETLA25-CHC	Esthetic Angled Titanium Abutment 25° CHC	85
7363	EA15-1.5CHC	Esthetic Anatomic Angled Ti Abutment 15° CHC H1.5	85
7364	EA15-2.5CHC	Esthetic Anatomic Angled Ti Abutment 15° CHC H2.5	85
7365	EA15-3.5CHC	Esthetic Anatomic Angled Ti Abutment 15° CHC H3.5	85
7366	EA25-1.5CHC	Esthetic Anatomic Angled Ti Abutment 25° CHC H1.5	85
7367	EA25-2.5CHC	Esthetic Anatomic Angled Ti Abutment 25° CHC H2.5	85
7368	EA25-3.5CHC	Esthetic Anatomic Angled Ti Abutment 25° CHC H3.5	85
7370	ETWASP1-CHC	Esthetic Straight Wide Abutment H1.0mm CHC	84
7371	ETWASP2-CHC	Esthetic Straight Wide Abutment H2.0mm CHC	84
7372	ETWASP3-CHC	Esthetic Straight Wide Abutment H3.0mm CHC	84
7373	ETWASP4-CHC	Esthetic Straight Wide Abutment H4.0mm CHC	84
7374	ETWASP5-CHC	Esthetic Straight Wide Abutment H5.0mm CHC	84
7383	ETLAS4.0-CHC	Esthetic Standard Abutment D4.0 CHC	84
7400	RS-CHC	Retrieval Screw CHC	73
7403	TB1-CHC	Titanium Ball Abutment 2.5mm L1mm CHC	83



REF. NO.	CODE	PRODUCT DESCRIPTION	PAGE NO.
7404	TB2-CHC	Titanium Ball Abutment 2.5mm L 2mm CHC	83
7405	TB3-CHC	Titanium Ball Abutment 2.5mm L 3mm CHC	83
7406	TB4-CHC	Titanium Ball Abutment 2.5mm L 4mm CHC	83
7407	TB5-CHC	Titanium Ball Abutment 2.5mm L 5mm CHC	83
7470	AK0.5-C-CHC	AlphaLoC Kit 0.5 mm C CHC	82
7471	AK1-C-CHC	AlphaLoC Kit 1.0 mm C CHC	82
7472	AK2-C-CHC	AlphaLoC Kit 2.0 mm C CHC	82
7473	AK3-C-CHC	AlphaLoC Kit 3.0 mm C CHC	82
7474	AK4-C-CHC	AlphaLoC Kit 4.0 mm C CHC	82
7475	AK5-C-CHC	AlphaLoC Kit 5.0 mm C CHC	82
7482	AU-17-1.5-CHC	Alpha Universe 17° H1.5mm CHC	76
7483	AU-17-2.5-CHC	Alpha Universe 17° H2.5mm CHC	76
7484	AU-17-3.5-CHC	Alpha Universe 17° H3.5mm CHC	76
7487	AU-30-1.5-CHC	Alpha Universe 30° H1.5mm CHC	76
7488	AU-30-2.5-CHC	Alpha Universe 30° H2.5mm CHC	76
7489	AU-30-3.5-CHC	Alpha Universe 30° H3.5mm CHC	76
9300	MultiNeO NH	MultiNeO NH C D3.2mm L10.0mm	34
9301	MultiNeO NH	MultiNeO NH C D3.2mm L11.5mm	34
9303	MultiNeO NH	MultiNeO NH C D3.2mm L13.0mm	34
9306	MultiNeO NH	MultiNeO NH C D3.2mm L16.0mm	34
9308	MultiNeO NH	MultiNeO NH C D3.2mm L8.0mm	34
9320	MultiNeO NH	MultiNeO NH C D3.5mm L10.0mm	34
9321	MultiNeO NH	MultiNeO NH C D3.5mm L11.5mm	34
9323	MultiNeO NH	MultiNeO NH C D3.5mm L13.0mm	34
9326	MultiNeO NH	MultiNeO NH C D3.5mm L16.0mm	34
9328	MultiNeO NH	MultiNeO NH C D3.5mm L8.0mm	34
9330	MultiNeO NH	MultiNeO NH CS D3.75mm L10.0mm	34
9331	MultiNeO NH	MultiNeO NH CS D3.75mm L11.5mm	34
9333	MultiNeO NH	MultiNeO NH CS D3.75mm L13.0mm	34
9336	MultiNeO NH	MultiNeO NH CS D3.75mm L16.0mm	34
9338	MultiNeO NH	MultiNeO NH CS D3.75mm L8.0mm	34
9340	MultiNeO NH	MultiNeO NH CS D4.2mm L10.0mm	34
9341	MultiNeO NH	MultiNeO NH CS D4.2mm L11.5mm	34
9343	MultiNeO NH	MultiNeO NH CS D4.2mm L13.0mm	34
9346	MultiNeO NH	MultiNeO NH CS D4.2mm L16.0mm	34
9348	MultiNeO NH	MultiNeO NH CS D4.2mm L8.0mm	34
9350	MultiNeO NH	MultiNeO NH CS D5.0mm L10.0mm	34
9351	MultiNeO NH	MultiNeO NH CS D5.0mm L11.5mm	34
9353	MultiNeO NH	MultiNeO NH CS D5.0mm L13.0mm	34
9358	MultiNeO NH	MultiNeO NH CS D5.0mm L8.0mm	34
65003	TPS	Tissue Punch Small	123
65004	TPL	Tissue Punch Large	123
65005	CDS	Crestal Drill Small	123
65006	CDL	Crestal Drill Large	123
65007	CD2-8	Surgical Drill D2.0mm - L8mm	123

REF. NO.	CODE	PRODUCT DESCRIPTION	PAGE NO.
65008	CD2-10	Surgical Drill D2.0mm - L10mm	123
65009	CD2-11.5	Surgical Drill D2.0mm - L11.5mm	123
65010	CD2-13	Surgical Drill D2.0mm - L13mm	123
65011	CD2-16	Surgical Drill D2.0mm - L16mm	123
65012	CD2.8-8	Surgical Drill D2.8mm - L8mm	123
65013	CD2.8-10	Surgical Drill D2.8mm - L10mm	123
65014	CD2.8-11.5	Surgical Drill D2.8mm - L11.5mm	123
65015	CD2.8-13	Surgical Drill D2.8mm - L13mm	123
65016	CD2.8-16	Surgical Drill D2.8mm - L16mm	123
65017	CD3.2-8	Surgical Drill D3.2mm - L8mm	123
65018	CD3.2-10	Surgical Drill D3.2mm - L10mm	123
65019	CD3.2-11.5	Surgical Drill D3.2mm - L11.5mm	123
65020	CD3.2-13	Surgical Drill D3.2mm - L13mm	123
65021	CD3.2-16	Surgical Drill D3.2mm - L16mm	123
65022	CD3.6-8	Surgical Drill D3.6mm - L8mm	123
65023	CD3.6-10	Surgical Drill D3.6mm - L10mm	123
65024	CD3.6-11.5	Surgical Drill D3.6mm - L11.5mm	123
65025	CD3.6-13	Surgical Drill D3.6mm - L13mm	123
65026	CD3.6-16	Surgical Drill D3.6mm - L16mm	123
65027	CD4.1-8	Surgical Drill D4.1mm - L8mm	123
65028	CD4.1-10	Surgical Drill D4.1mm - L10mm	123
65029	CD4.1-11.5	Surgical Drill D4.1mm - L11.5mm	123
65030	CD4.1-13	Surgical Drill D4.1mm - L13mm	123
65031	CD4.1-16	Surgical Drill D4.1mm - L16mm	123
65032	CD4.5-8	Surgical Drill D4.5mm - L8mm	123
65033	CD4.5-10	Surgical Drill D4.5mm - L10mm	123
65034	CD4.5-11.5	Surgical Drill D4.5mm - L11.5mm	123
65035	CD4.5-13	Surgical Drill D4.5mm - L13mm	123
65036	CD4.5-16	Surgical Drill D4.5mm - L16mm	123
65037	IMS	Implant Mount Small	123
65038	IML	Implant Mount Large	123
65039	IMHS	Implant Mount Screw	123
65042	IMX	Implant mount extention	123
65044	HIA	Handpiece Insertion Adopter	123
65045	IME	Implant Mount Extractor	123
65047	LP	Lateral Pin	123
65048	CPS	Crestal Pin Small	123
65049	CPL	Crestal Pin Large	123
65050	MCD1.5	Milling Drill D1.5mm	123
65055	IMC	Implant Mount CHC	123
65056	IMCS	Implant Mount Screw CHC	123
65057	SAD	Sleeve L/S Adaptor Driver	123
65058	SLSA	Small Sleeve for Adaptor	123
65061	IMCD	Implant Mount CHC Driver	123
65062	IMSD	Implant Mount Int. Hex Driver Small	123

REF. NO.	CODE	PRODUCT DESCRIPTION	PAGE NO.
65063	IMLD	Implant Mount Int. Hex Driver Large	123
65064	IMSS	Implant Mount CS Small	123
65065	IMSL	Implant Mount CS large	123
65070	CD2.4-8	Surgical Drill D2.4mm - L8mm	123
65071	CD2.4-10	Surgical Drill D2.4mm - L10mm	123
65072	CD2.4-11.5	Surgical Drill D2.4mm - L11.5mm	123
65073	CD2.4-13	Surgical Drill D2.4mm - L13mm	123
65074	CD2.4-16	Surgical Drill D2.4mm - L16mm	123
66012	SLS	Sleeve Small	124
66013	SLL	Sleeve Large	124
66014	SLSE	Securing Sleeve	124
05-0210	-	xenbone 0.5g/0.8cc 0.2 - 1.0mm	133
05-0512	-	xenbone 0.5g/1.2cc 0.5 - 1.2mm	133
05-1217	-	xenbone 0.5g/1.5cc 1.2 - 1.7mm	133
10-0210	-	xenbone 1.0g/1.5cc 0.2 - 1.0mm	133
10-0512	-	xenbone 1g/2.3cc 0.5 - 1.2mm	133
10-1217	-	xenbone 1.0g/3.0cc 1.2 - 1.7mm	133
20-0210	-	xenbone 2.0g/3.0cc 0.2 - 1.0mm	133
20-0512	-	xenbone 2.0g/4.5cc 0.5 - 1.2mm	133
20-1217	-	xenbone 2.0g/6.0cc 1.2 - 1.7mm	133
25-0210	-	xenbone 0.25g/0.45cc 0.2 - 1.0mm	133
25-0512	-	xenbone 0.25g/0.6cc 0.5 - 1.2mm	133
25-1217	-	xenbone 0.25g/0.75cc 1.2 - 1.7mm	133
4712C	MDRX1.5	Marking Drill-Sphere shape 1.5/L16	111
5480	OB8-0.75-CS	OMNIBASE base 0.75 -CS Long	66
5481	OB8-1.5-CS	OMNIBASE base 1.5 -CS Long	66
5482	OB8-2.5-CS	OMNIBASE base 2.5 -CS Long	66
5483	OB8-3.5-CS	OMNIBASE base 3.5 -CS Long	66
5484	OB8-4.5-CS	OMNIBASE base 4.5 -CS Long	66
5490	OB4.7-0.75-CS	OMNIBASE base 0.75 -CS Short	66
5491	OB4.7-1.5-CS	OMNIBASE base 1.5 -CS Short	66
5492	OB4.7-2.5-CS	OMNIBASE base 2.5 -CS Short	66
5493	OB4.7-3.5-CS	OMNIBASE base 3.5 -CS Short	66
5494	OB4.7-4.5-CS	OMNIBASE base 4.5 -CS Short	66
BLK8812	-	xenbone Block 8 x 8 x 12mm	133
BLK8825	-	xenbone Block 8 x 8 x 25mm	133
KIT#65000	GSTK-S	GSTK-Guided Surgery Tool Kit for sale-IH&CHC	121
KIT#65002	-	GSTK-Guided Surgery Tool Kit for sale-CHC+CS	121
KIT#65003	-	GSTK-Guided Surgery Tool Kit for sale-IH+CHC+CS	121
S05-0210	-	xenbone Syringe 0.5g/1.1cc 0.2 - 1.0mm	133
S05-0512	-	xenbone Syringe 0.5g/1.2cc	133
S05-1217	-	xenbone Syringe 0.5g/1.5cc 1.2 - 1.7mm	133
S25-0210	-	xenbone Syringe 0.25g/0.55cc 1.0 - 0.2mm	133
S25-0512	-	xenbone Syringe 0.25g/0.6cc	133
S25-1217	-	xenbone Syringe 0.25g/0.75cc 1.7 - 1.2mm	133

REF. NO.	CODE	PRODUCT DESCRIPTION	PAGE NO.
TG-1	TG-1	TG-1 15*20	136
TG-2	TG-2	TG-2 20*30	136
TG-3	TG-3	TG-3 30*40	136







Feel free to reach out to our Customer Service Team for further information. We are here for any help or support!

Scan the QR code to contact us!





**DESIGNED TO LAST. GUARANTEED FOR LIFE,  
FOR YOUR PEACE OF MIND.**

Alpha-Bio Tec's high-quality implants meet strict international standards!  
We provide you with a Lifetime Warranty for our wide range of implants.

The terms and conditions of the Lifetime Warranty are set out in the Alpha-Bio Tec. Warranty Program.

**Warranty:** Alpha-Bio Tec. warrants that all implants will be free of defects in materials and/or workmanship. This warranty applies to the original purchaser only. There are no warranties, express or implied, except this warranty, which is given in lieu of any other warranties, express or implied, including any implied warranty of fitness for a particular purpose.

In any case of a defect in the implant, subject to the terms and conditions of the Warranty Program, following the quality assurance procedures and to filling a complaint, Alpha-Bio Tec. shall credit the defective implant.

[Download the complaint form](#) from our website or contact our customer service team to receive it via e-mail.

**For more information about the Warranty Program and its terms and conditions, please contact our customer service team.**

**Important Notes:**

- Prior to using Alpha-Bio Tec's products please read the product's instructions for use.
- Alpha-Bio Tec continually strives to update and improve its products; hence we reserve the right to modify designs, products and/or techniques when needed.
- Alpha-Bio Tec. also reserves the right to update its prices, policies, and terms without prior notice.
- Product availability may vary in different countries.
- Some products may not be available for sales in the USA.
- In the event of a product defect, please notify Alpha-Bio Tec. in writing, prior to returning the product by filing a product complaint form.
- The purchaser assumes all risk and liabilities from the use of these products, whether used separately or in conjunction with products not of Alpha-Bio Tec's manufacture. Professional discretion is advised.
- Alpha-Bio Tec. strongly recommends the completion of post-graduate implant education and adherence to all technical procedures and instructions.
- Alpha-Bio Tec. products may be protected by more than one patent.



## Creating Smiles with Confidence

[www.alpha-bio.net](http://www.alpha-bio.net) | [info@alpha-bio.net](mailto:info@alpha-bio.net)

